

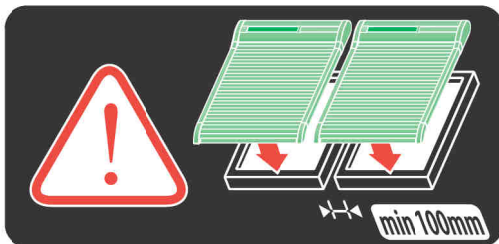

# ARZ Komfort Z-Wave Solar

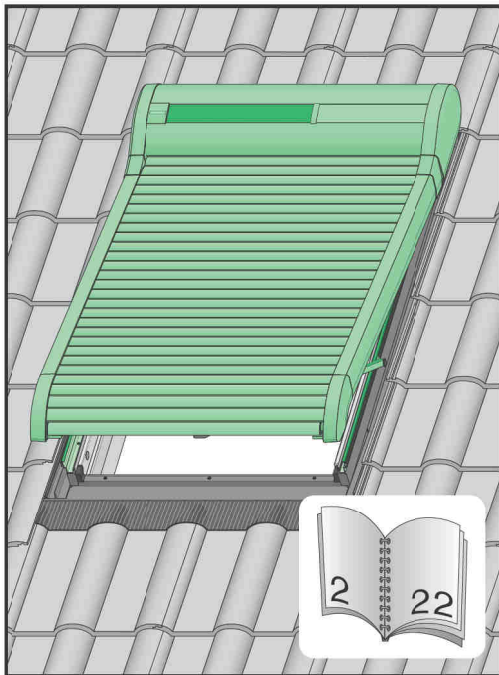

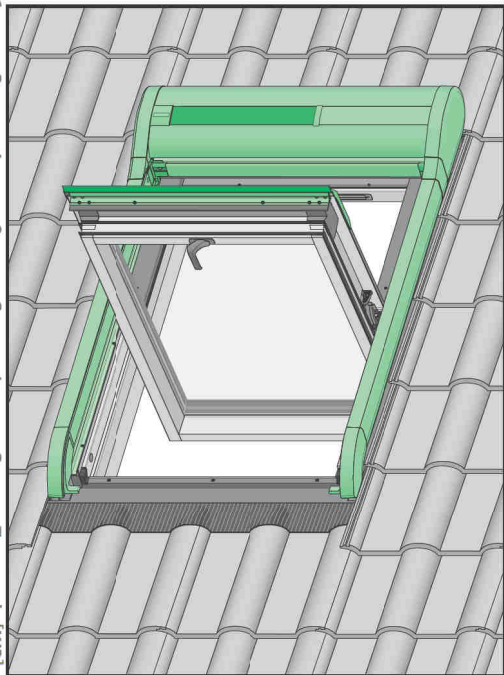
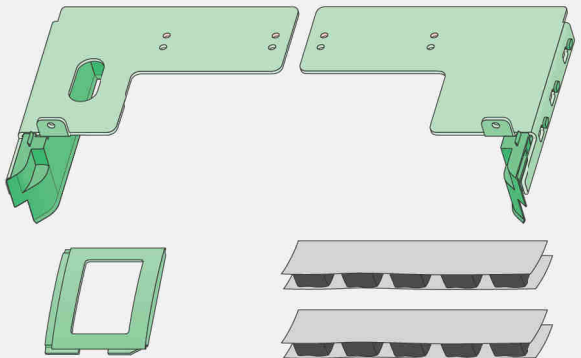
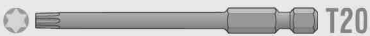
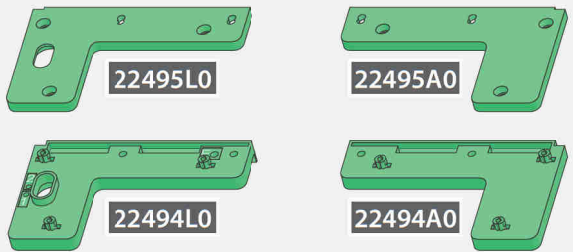
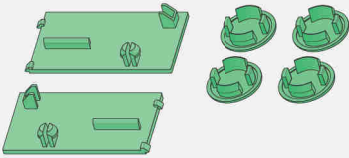
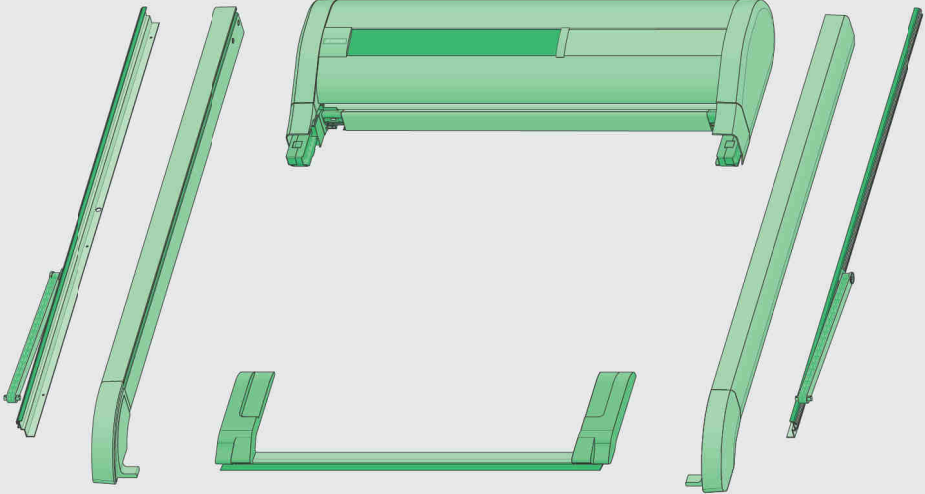

1

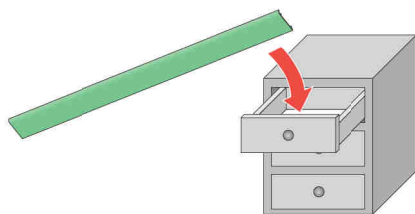
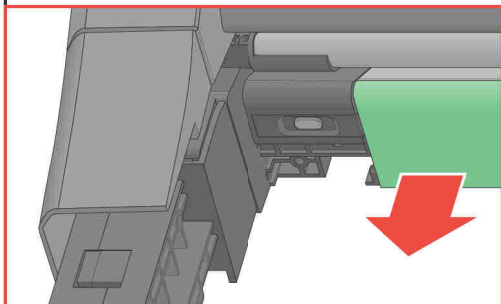
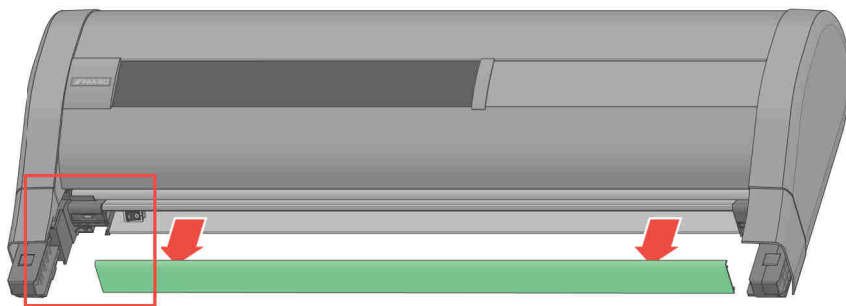

2

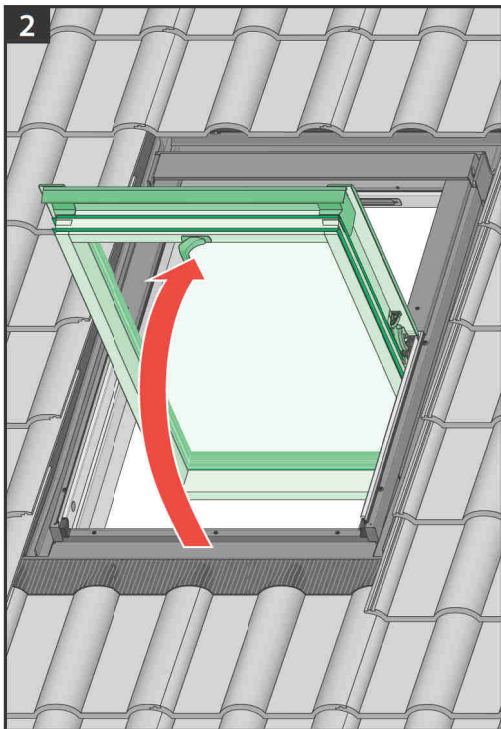

2\*

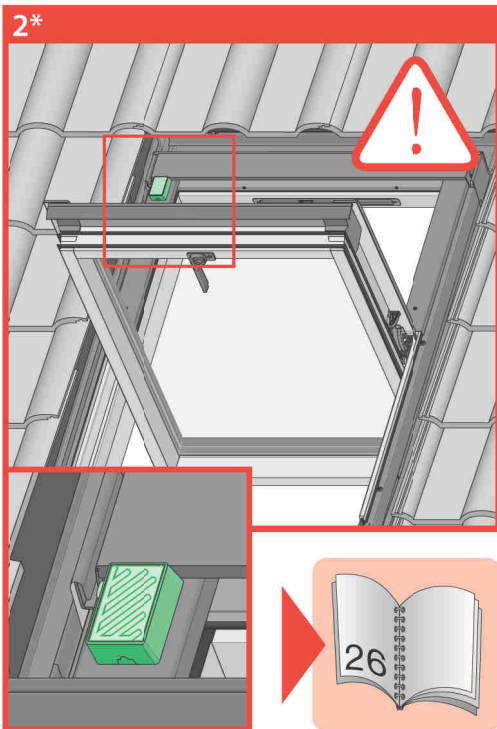

3

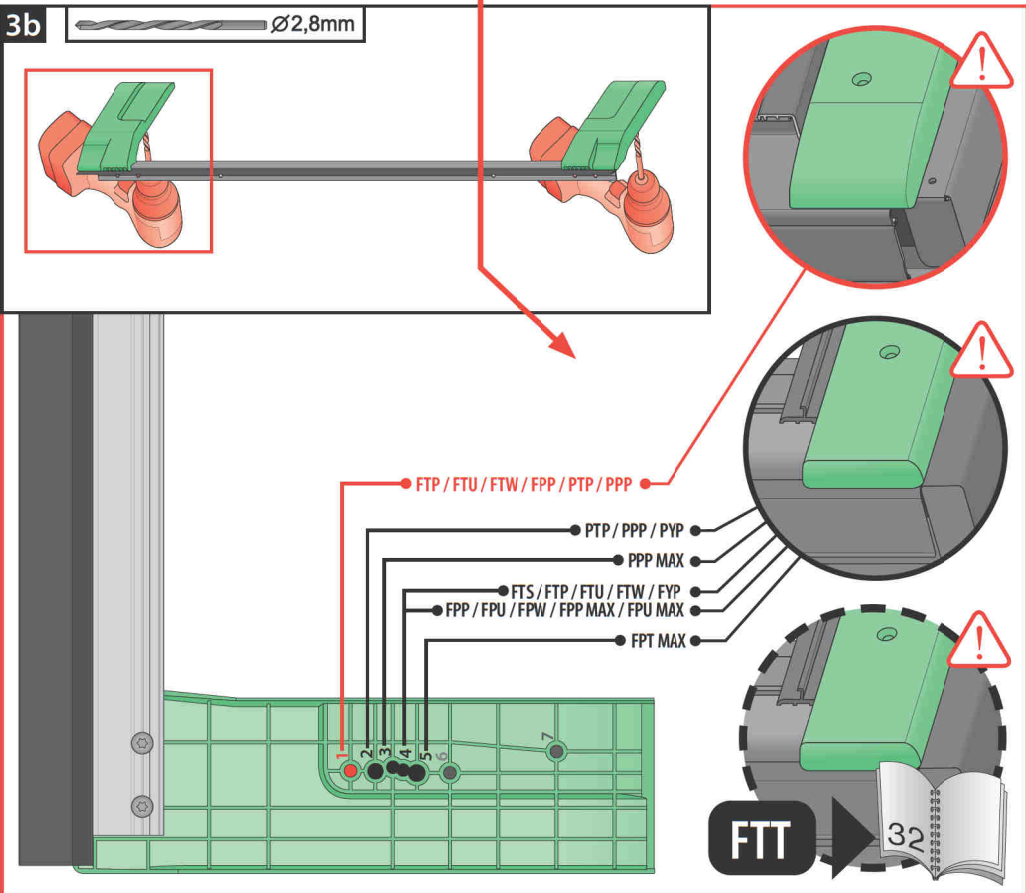
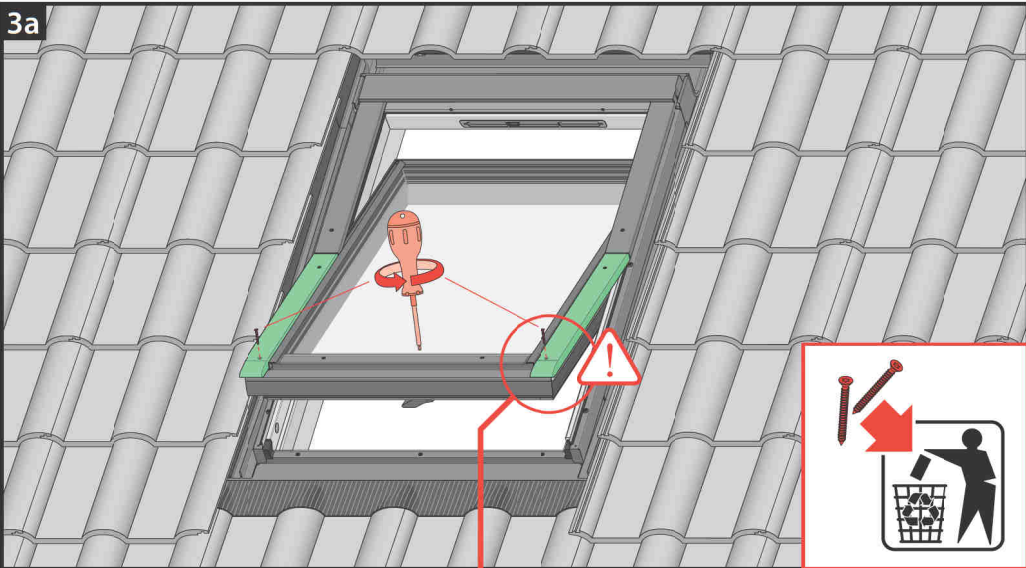

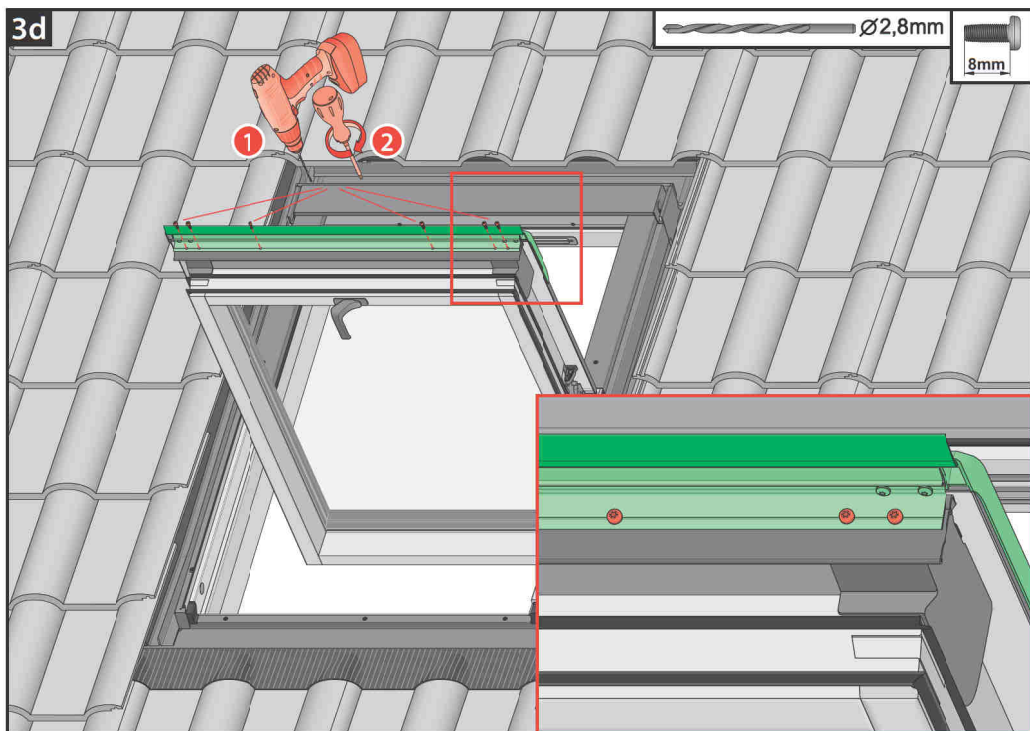
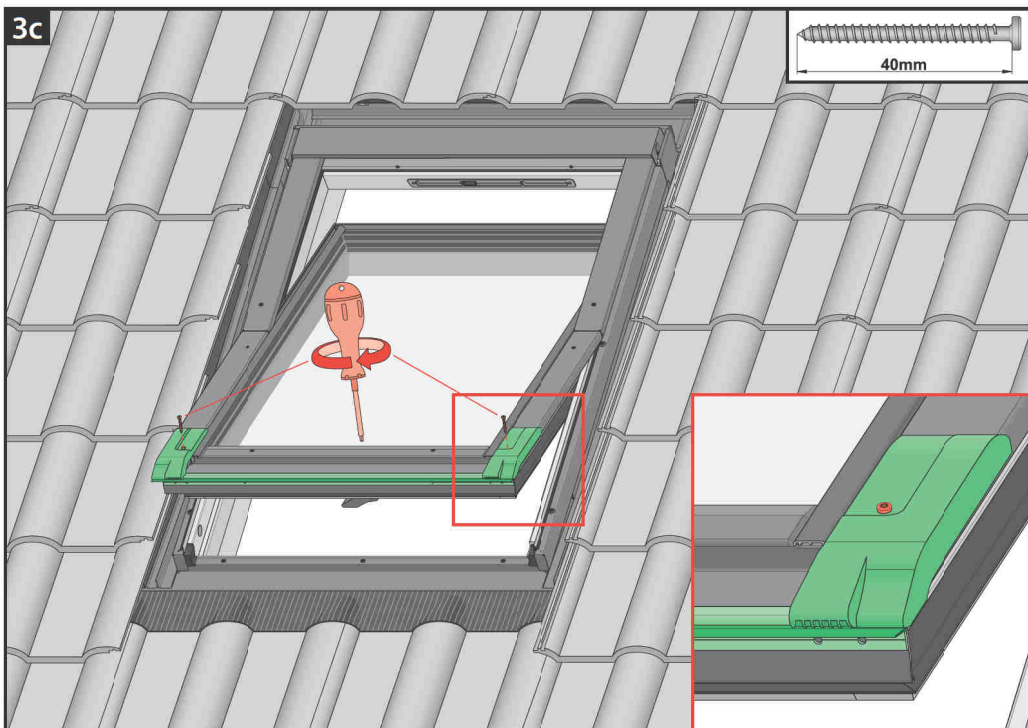

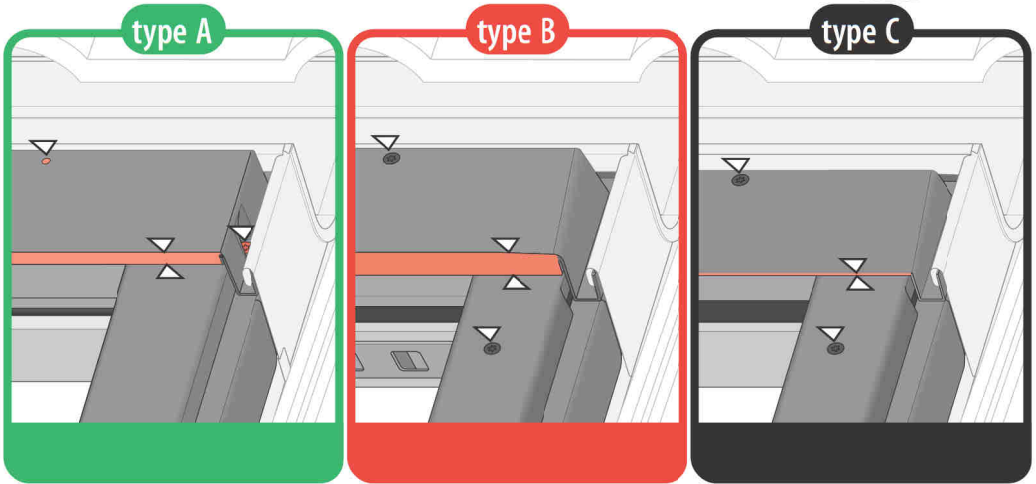
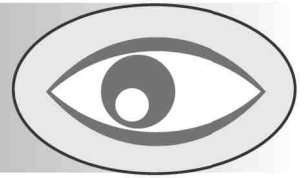

## 4a type A

Ø2,8mm

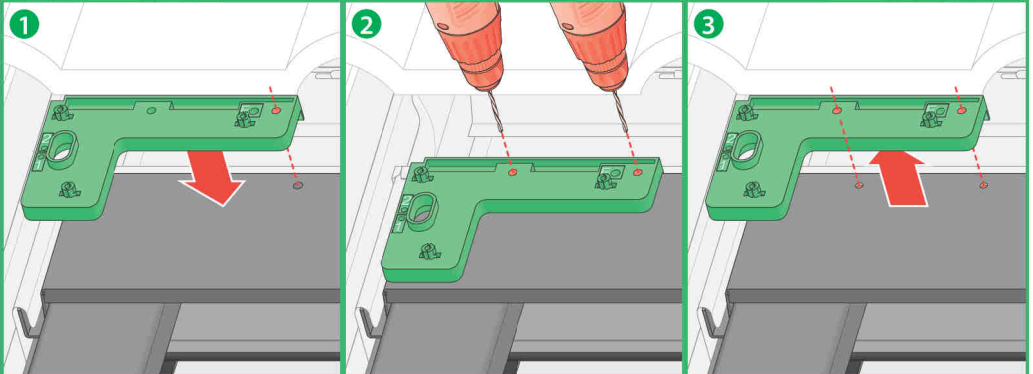
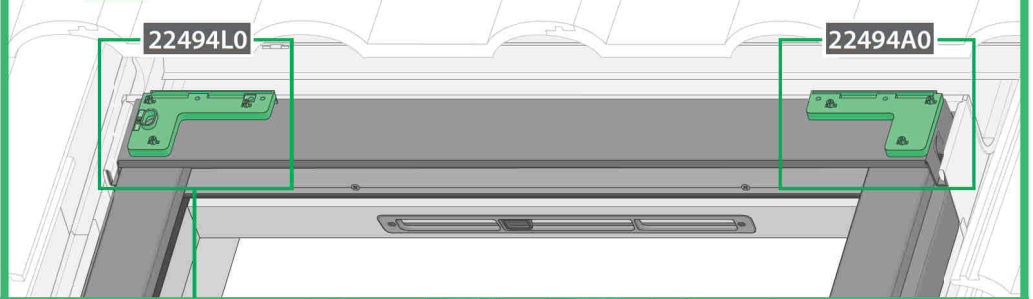

4b type B

Ø2,8mm

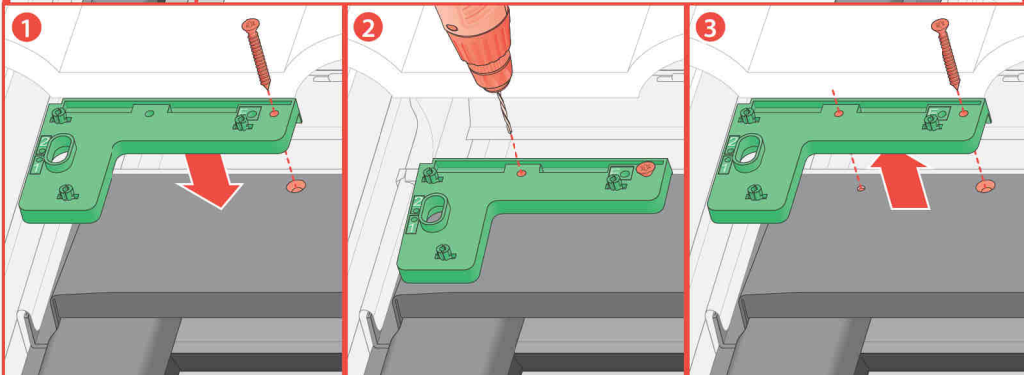
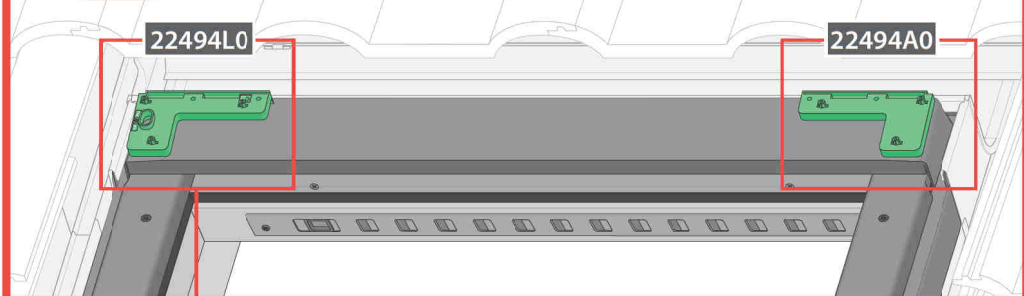

4c type C

Ø2,8mm

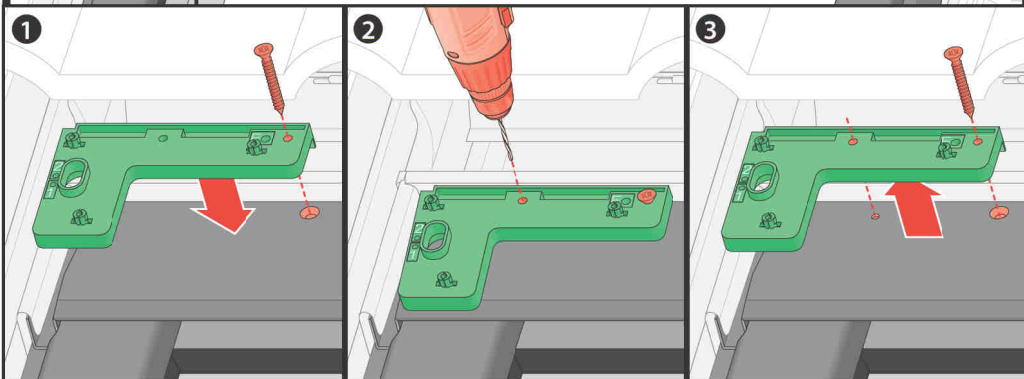
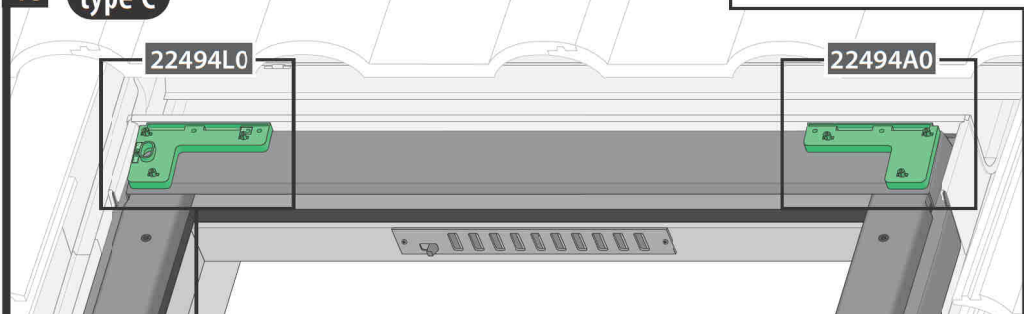

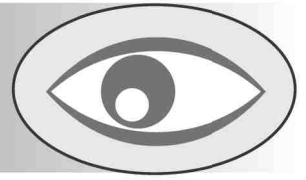

type A

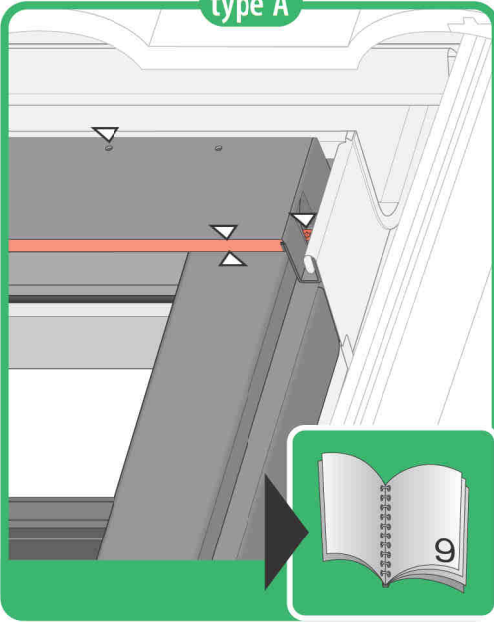

type B

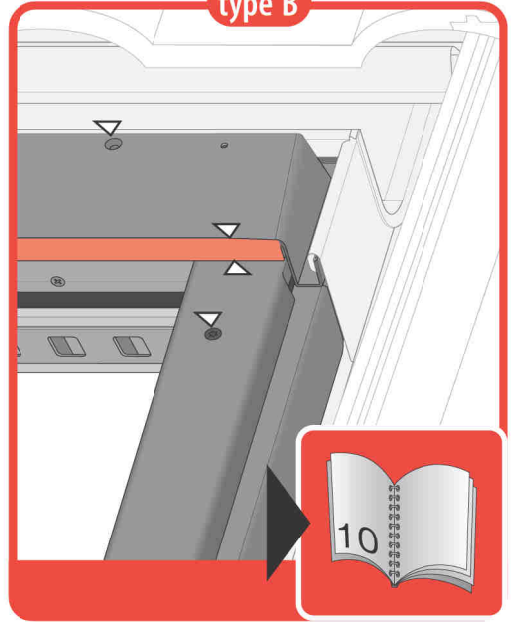

type C

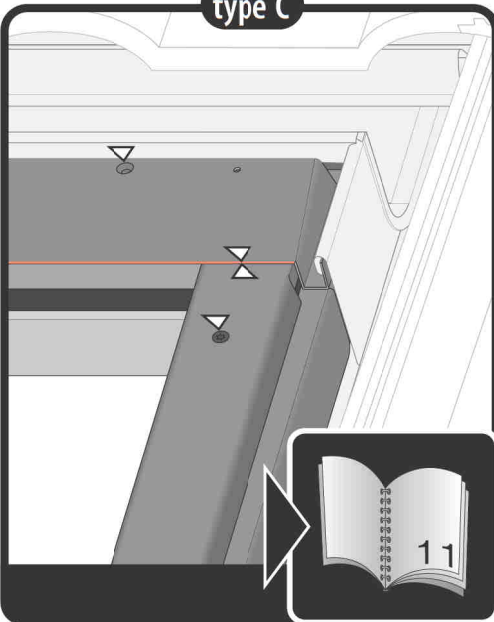

FTT

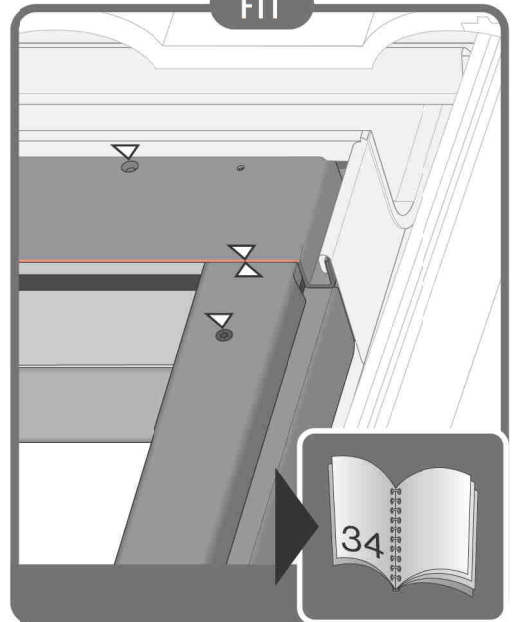

5a type A

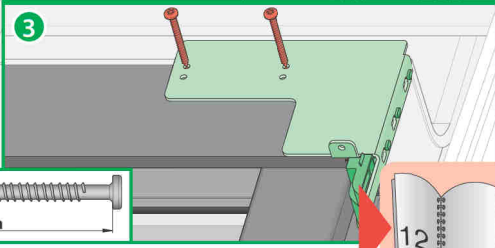
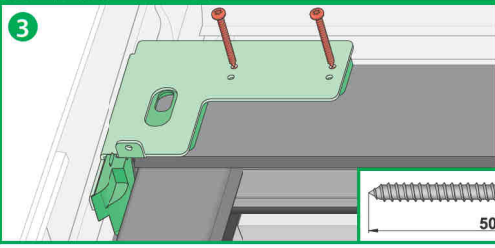
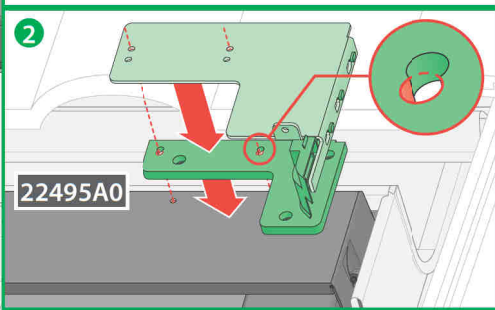
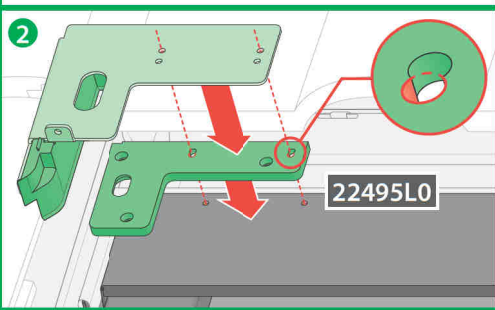
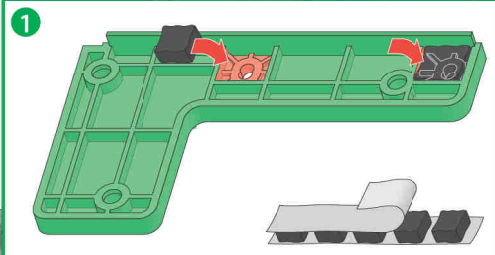
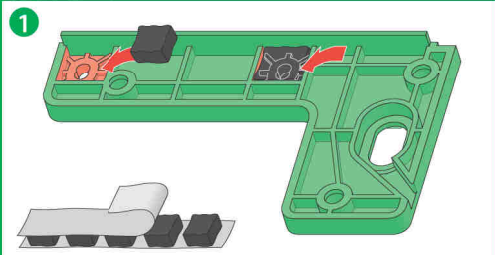
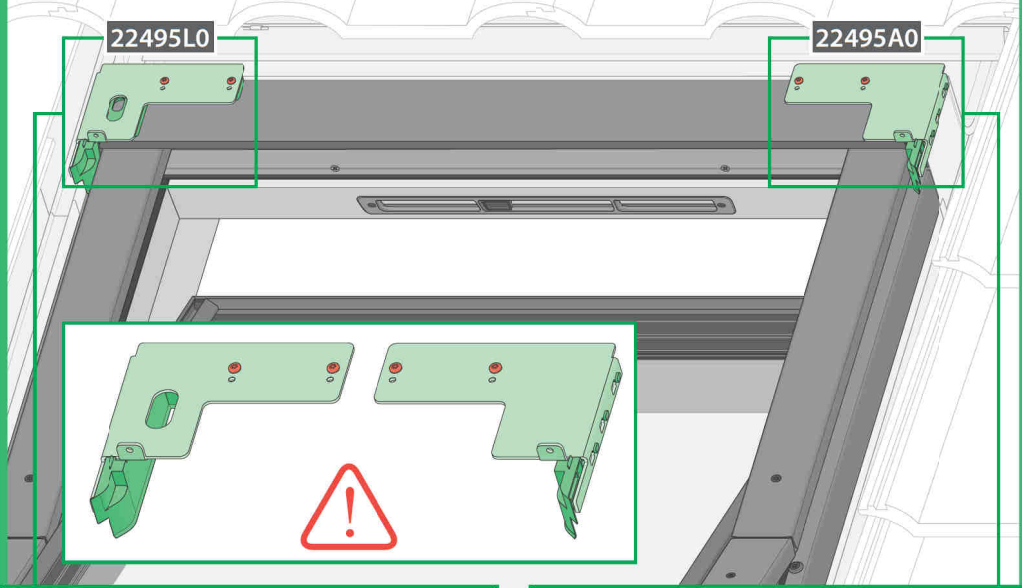

5b type B

22495L0

22495A0

FTS / FTP / FPP / FPP MAX  
FYP / FTP MAX

PTP / PPP / PPP MAX  
PYP

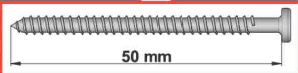
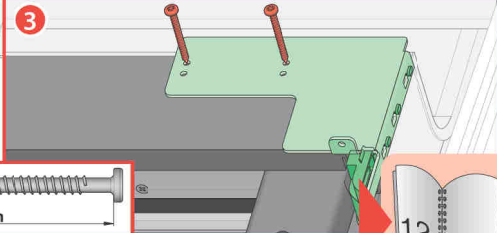
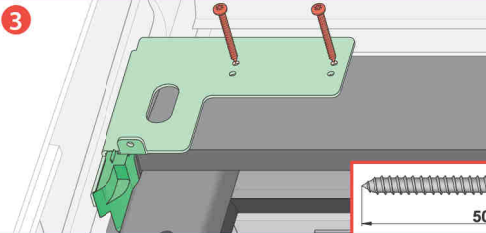
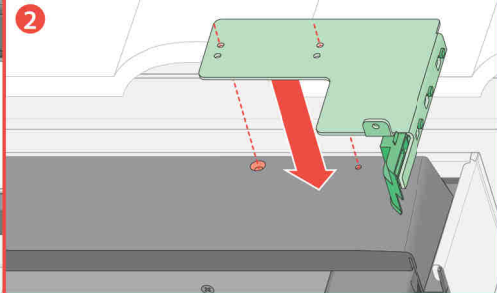
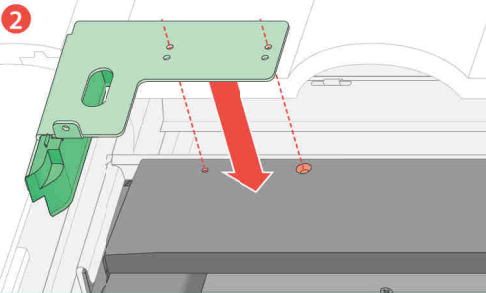
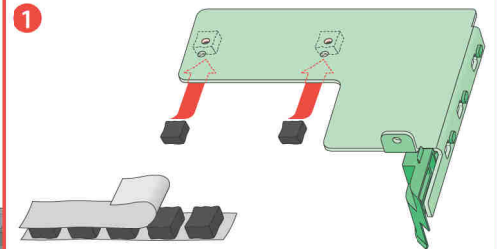
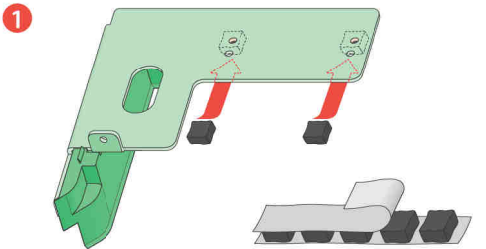
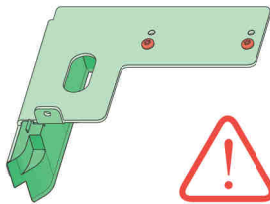
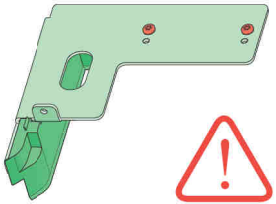

5c type C

22495L0

22494L0

22495A0

22494A0

FTS / FTP / FPP / FPP MAX  
FYP / FTP MAX

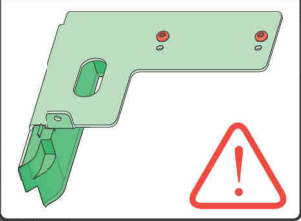

PTP / PPP / PPP MAX  
PYP

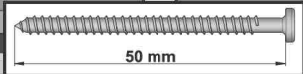
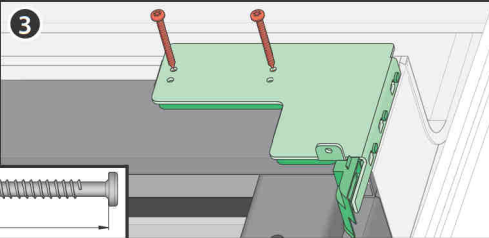
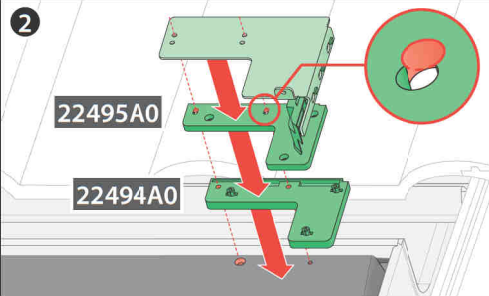
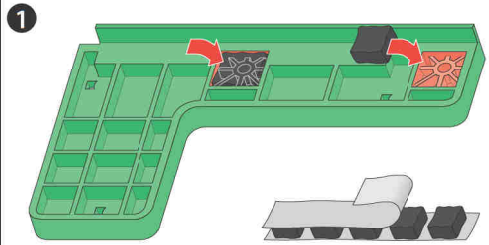
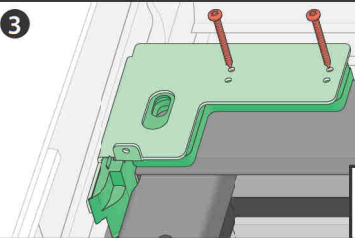
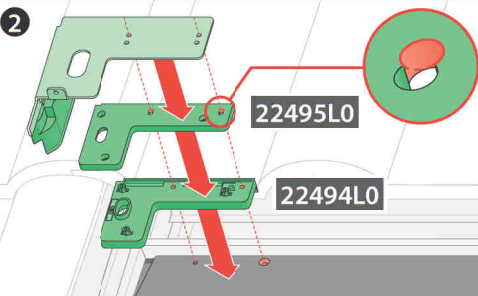
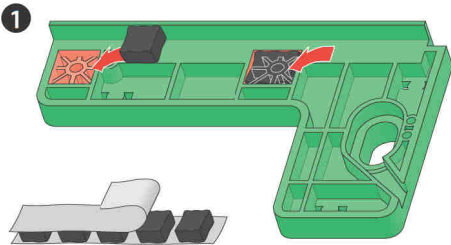
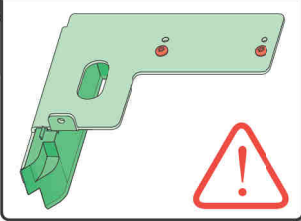

6a

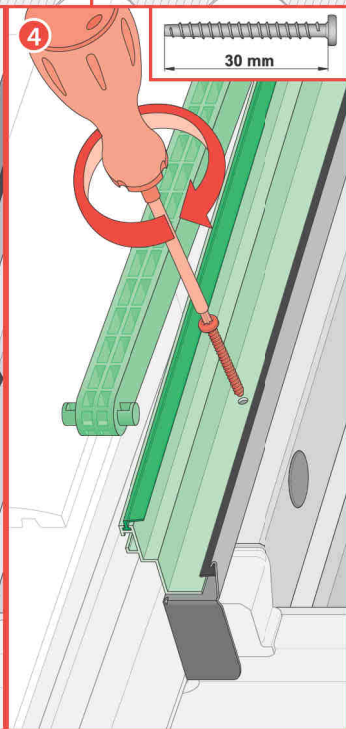
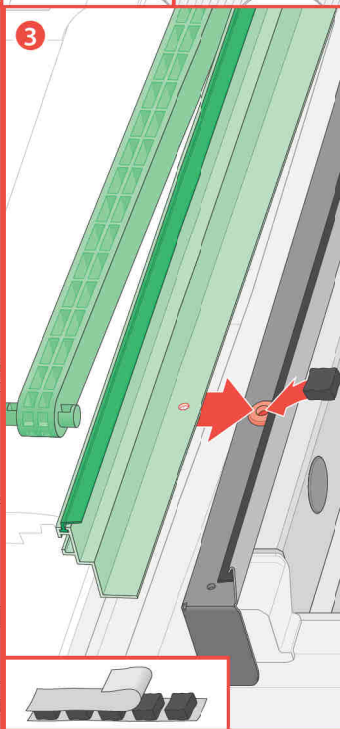
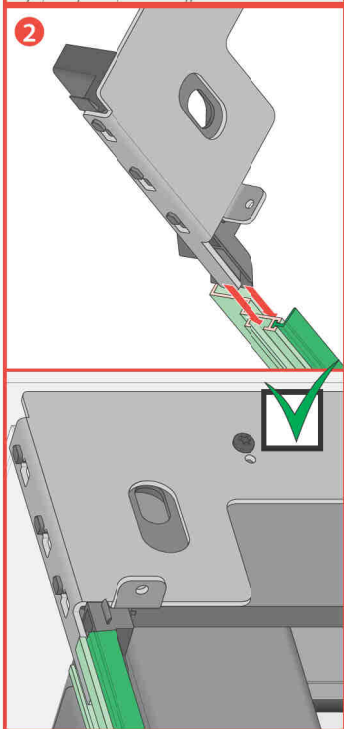
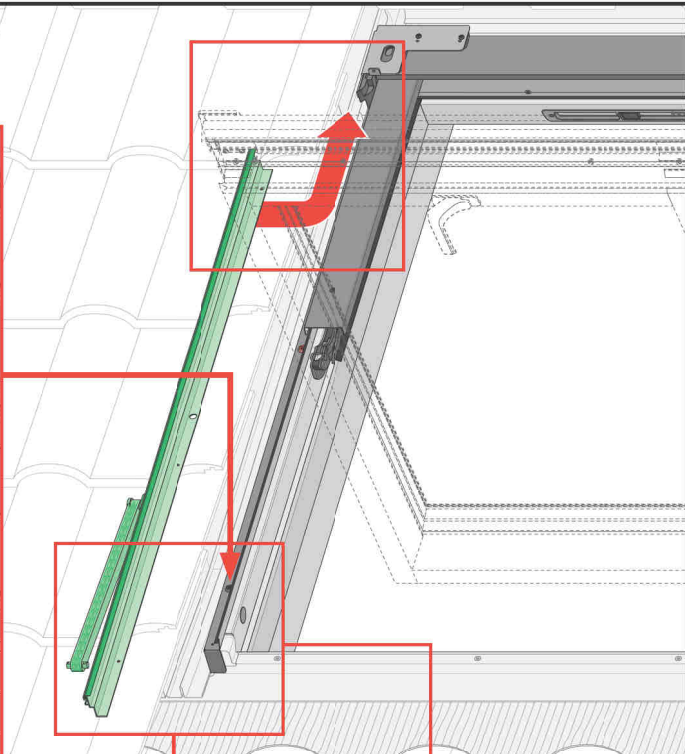
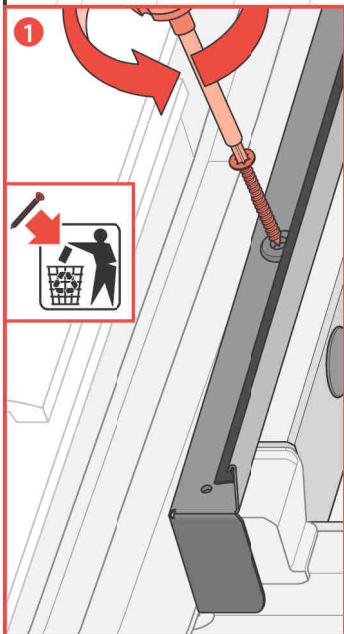

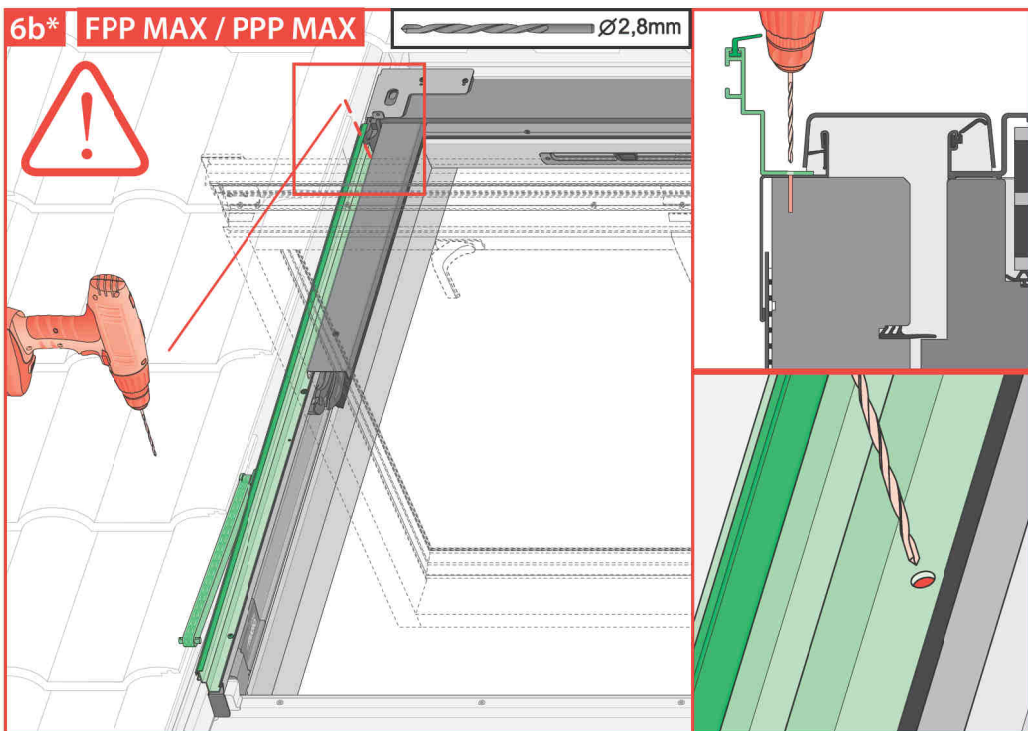
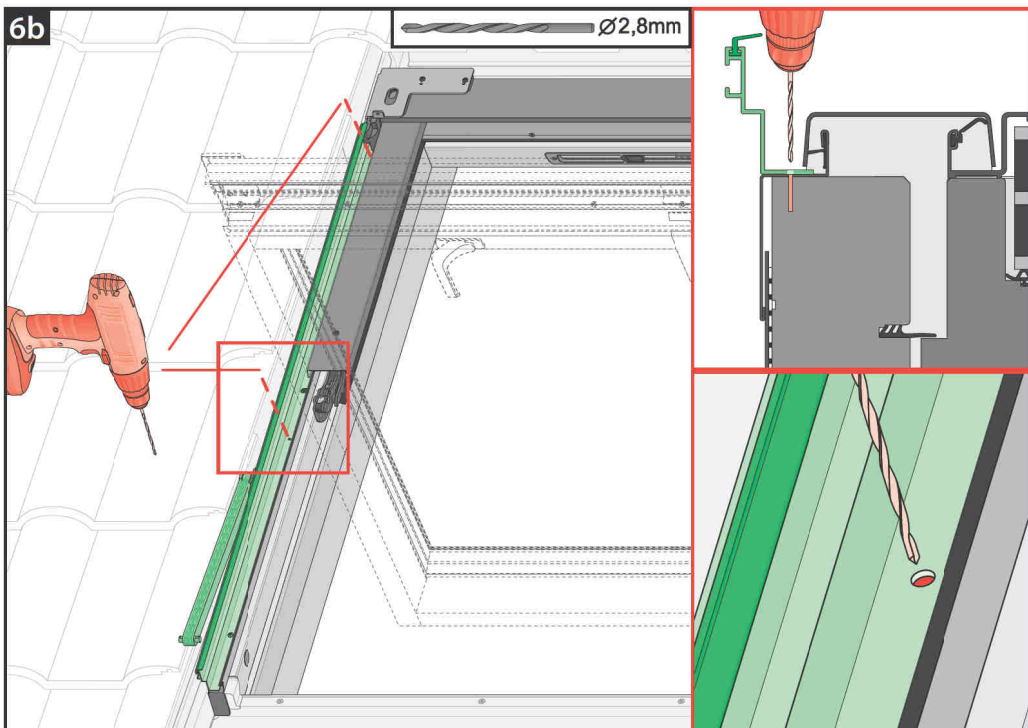

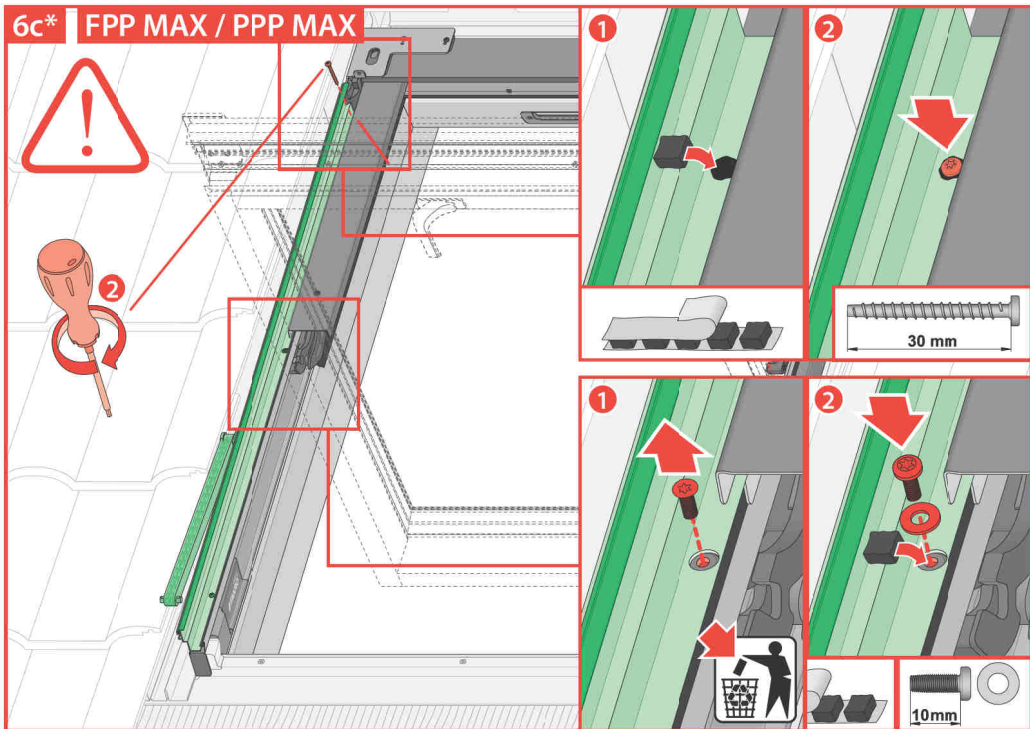
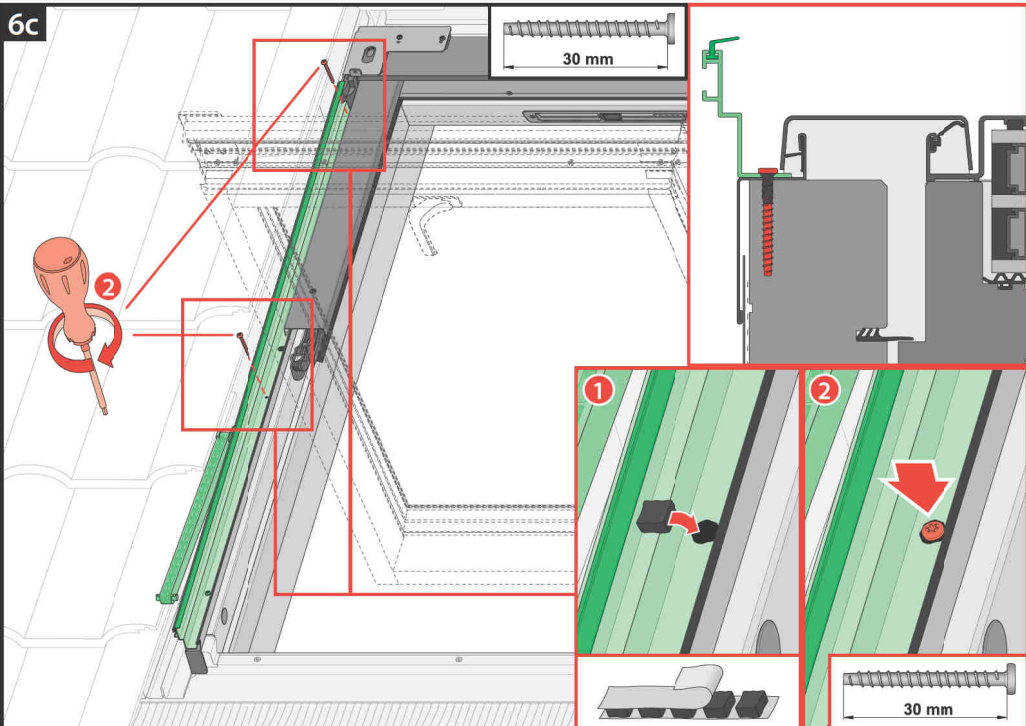

6d

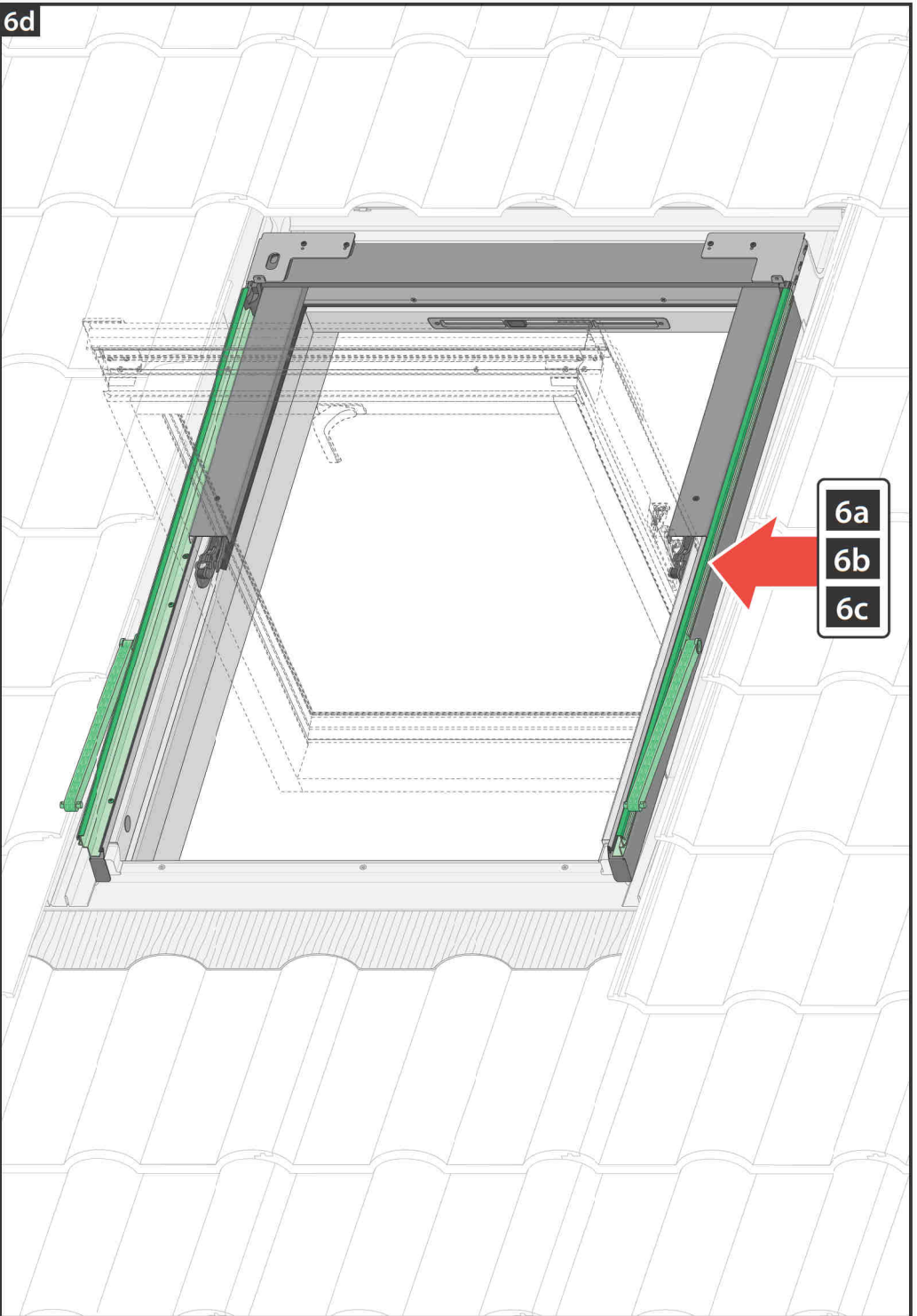

- 6a
- 6b
- 6c

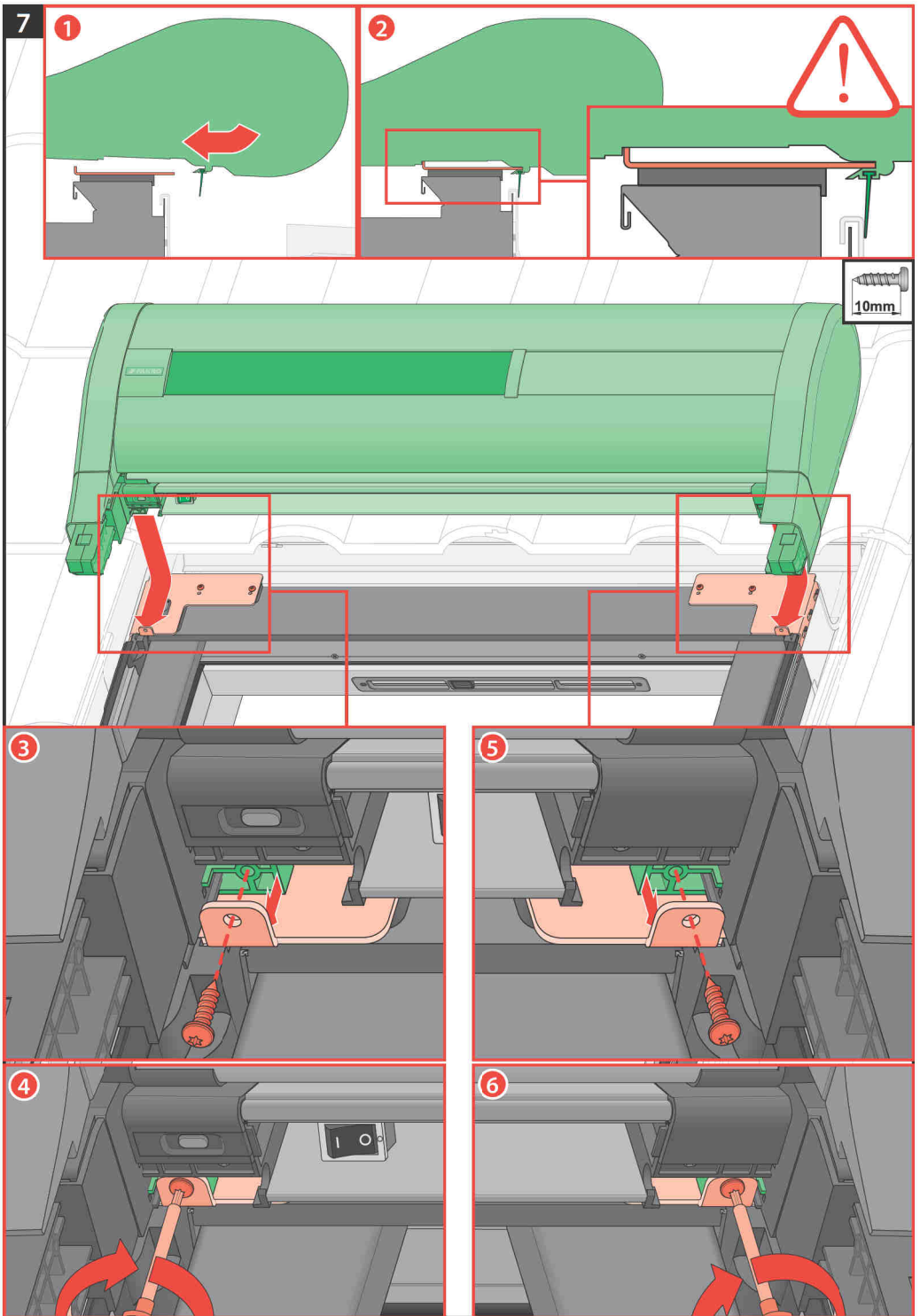

8

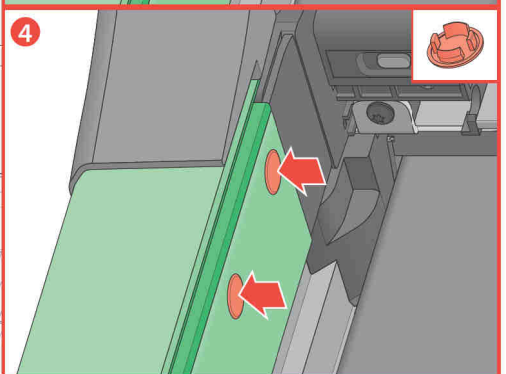
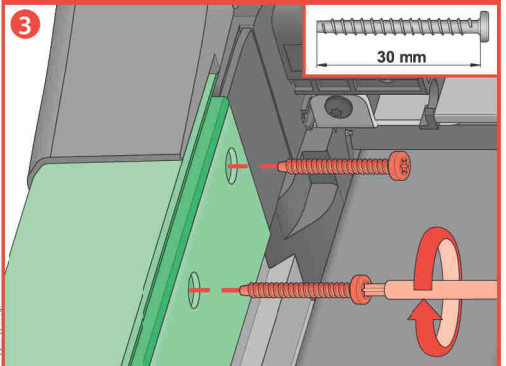
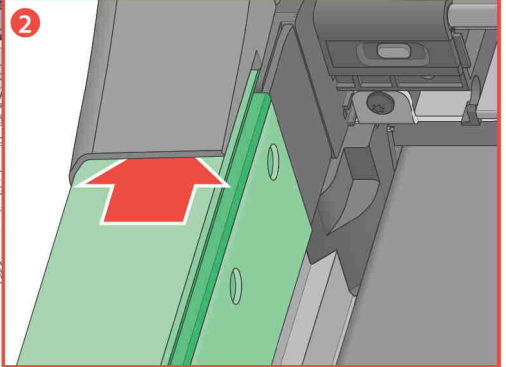
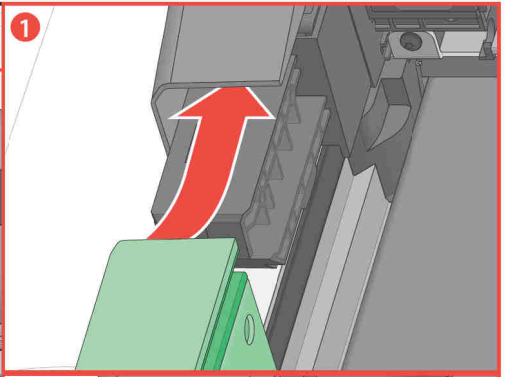

9

1

2

3

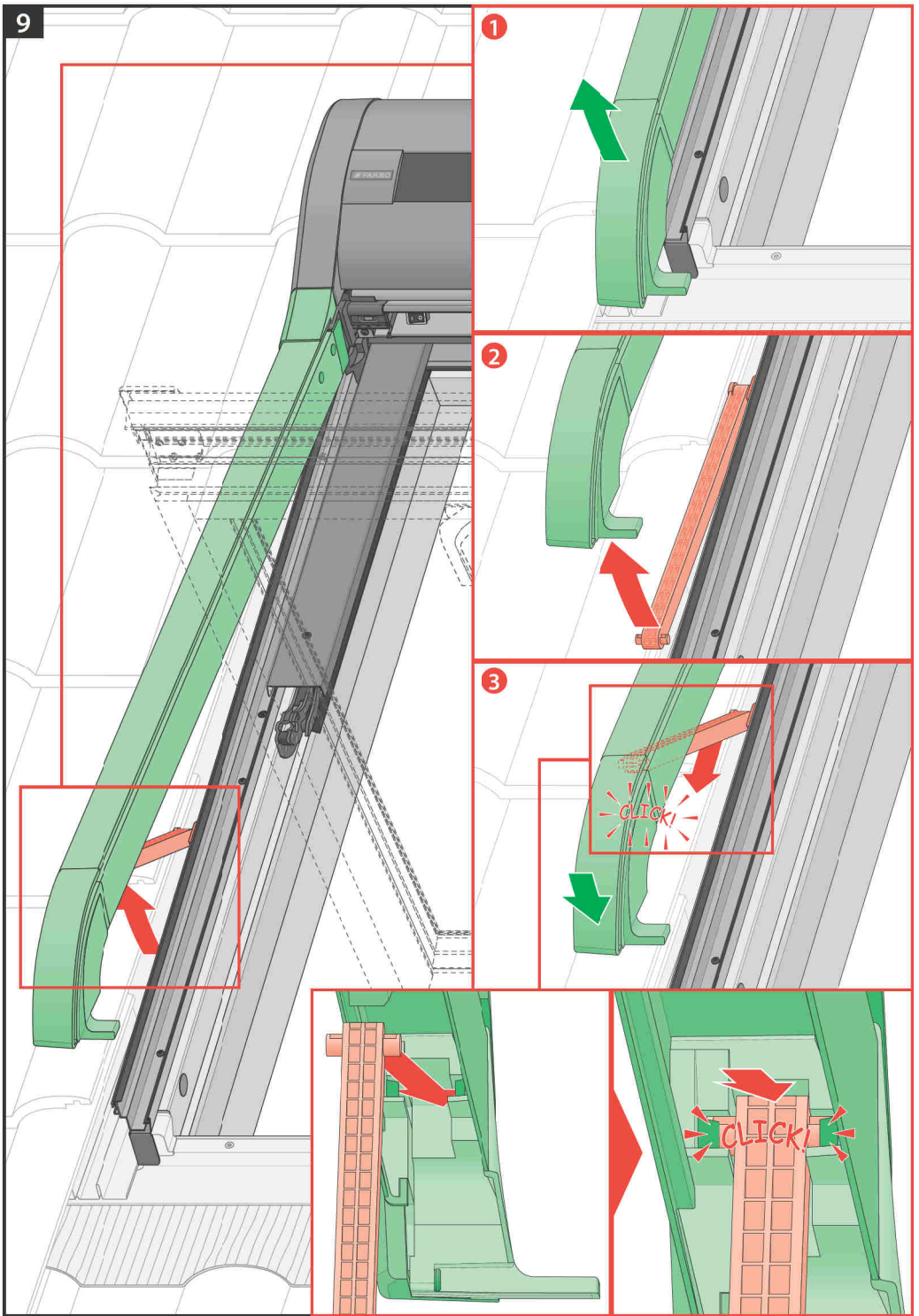

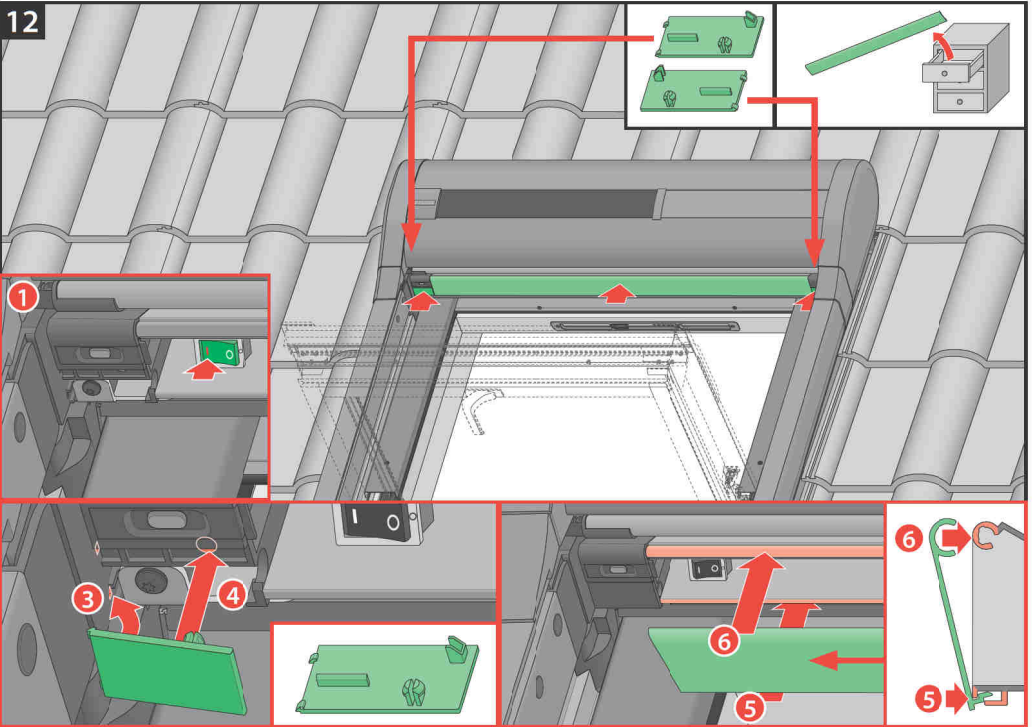
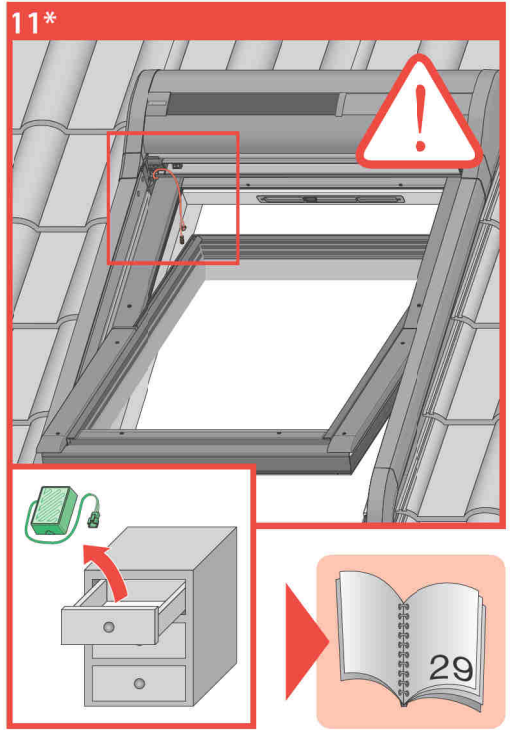
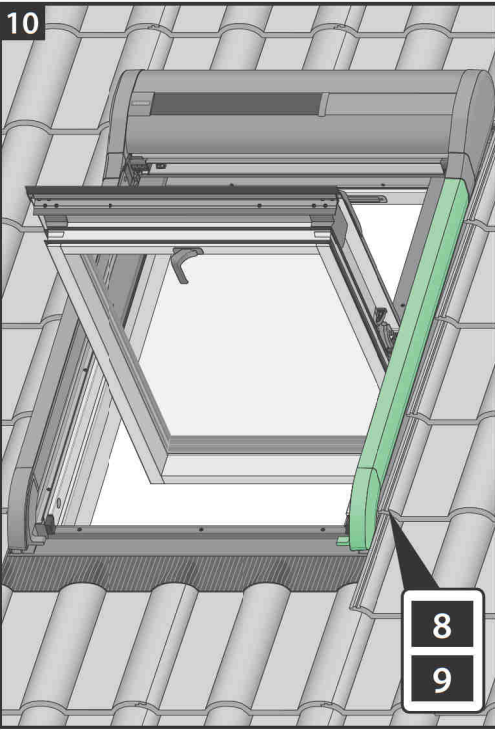

13a

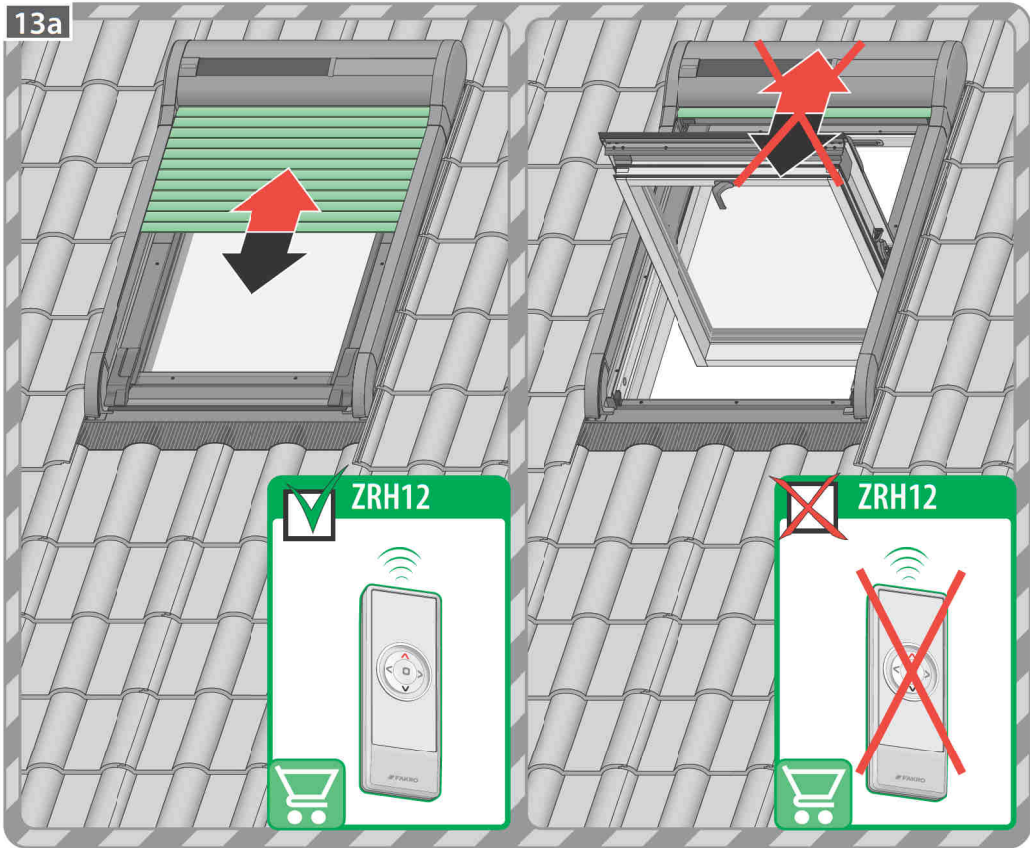

13b

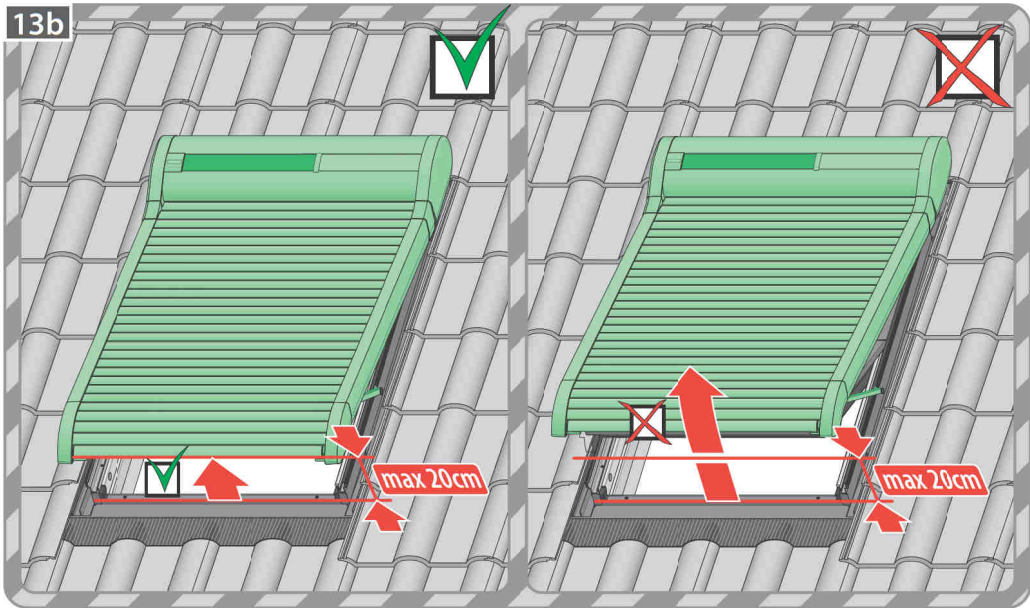

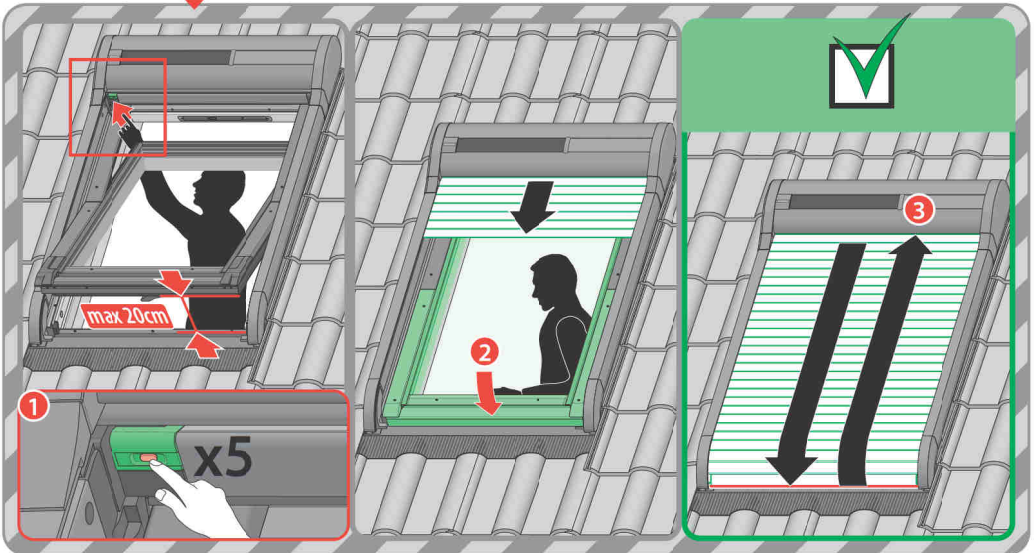
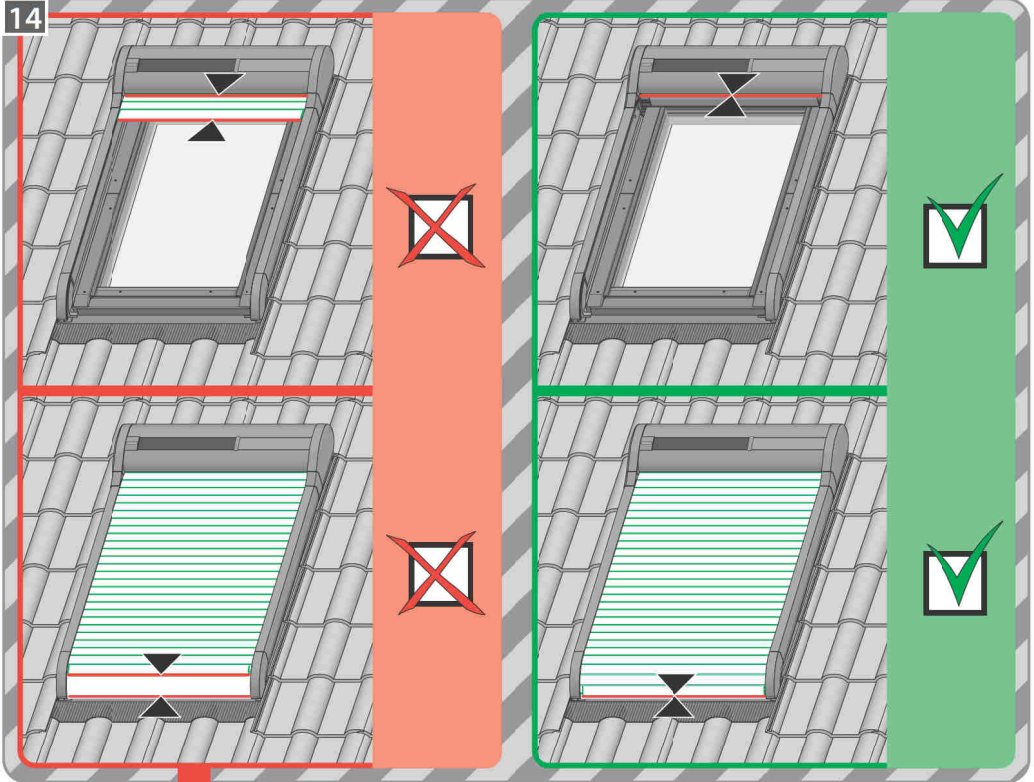

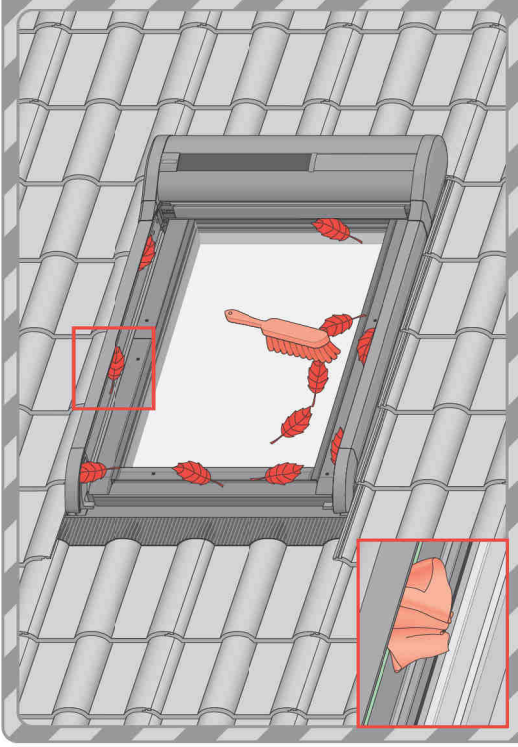
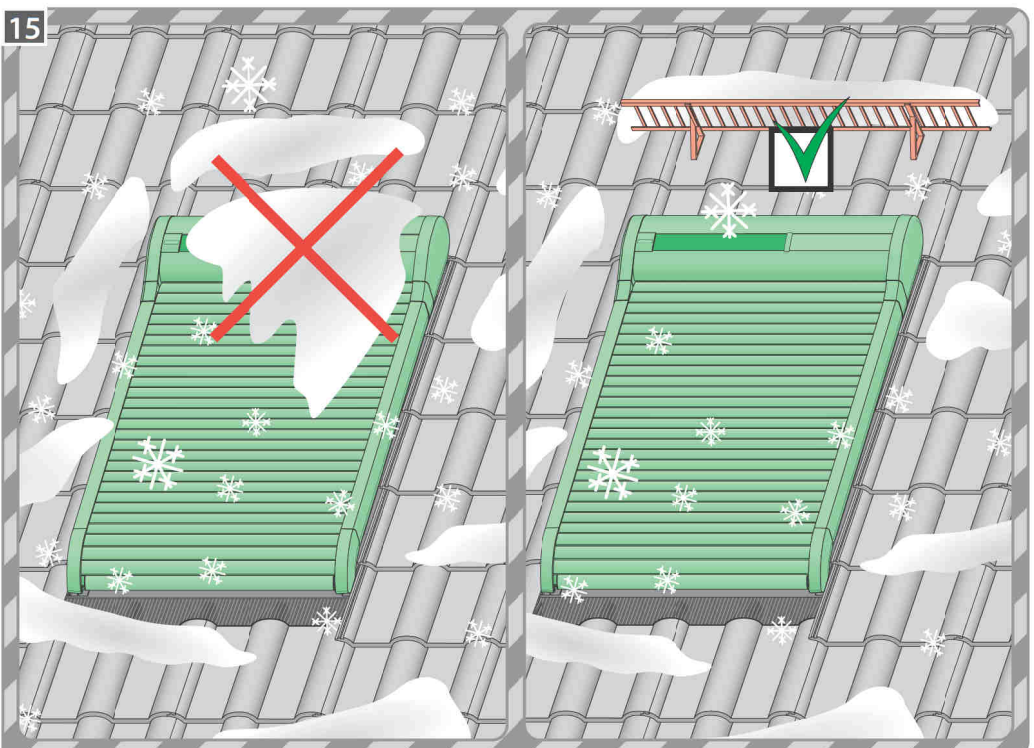

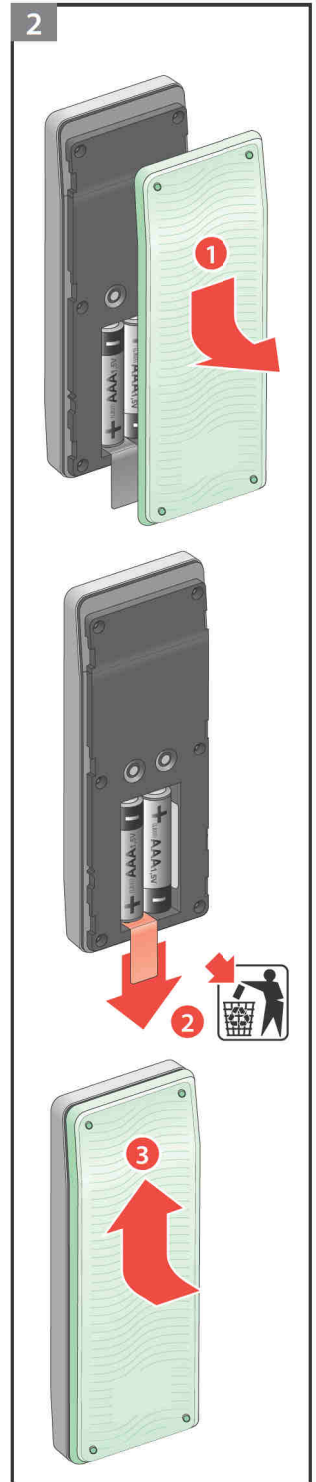
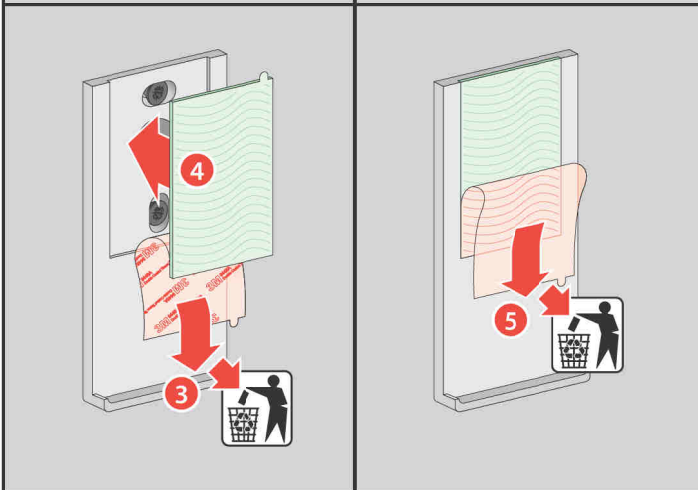
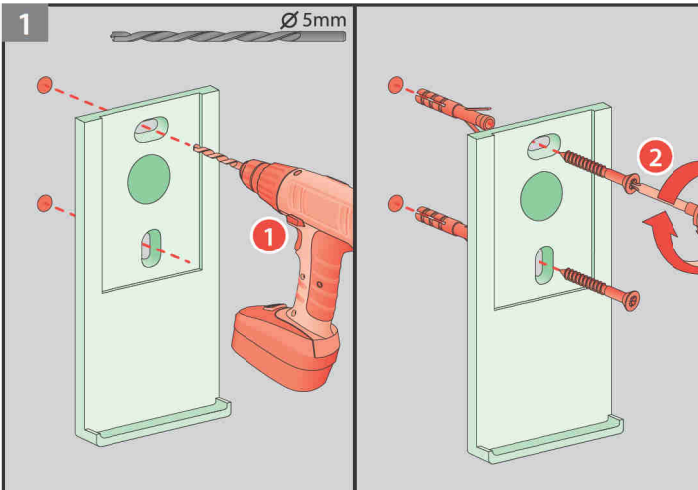

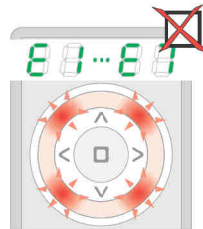
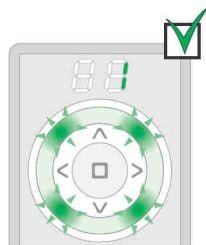
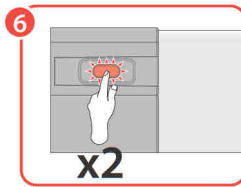
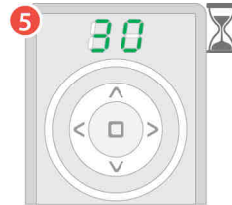
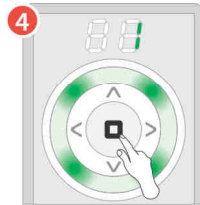
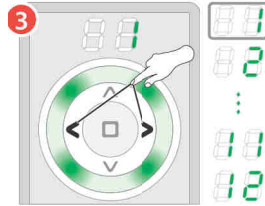
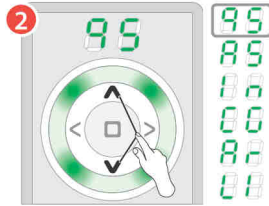
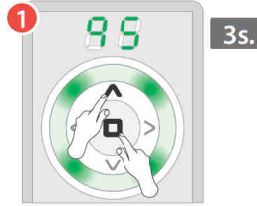
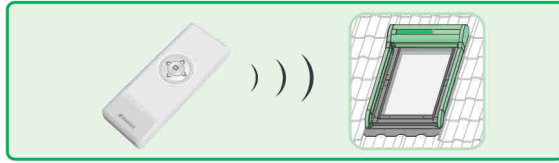

4a

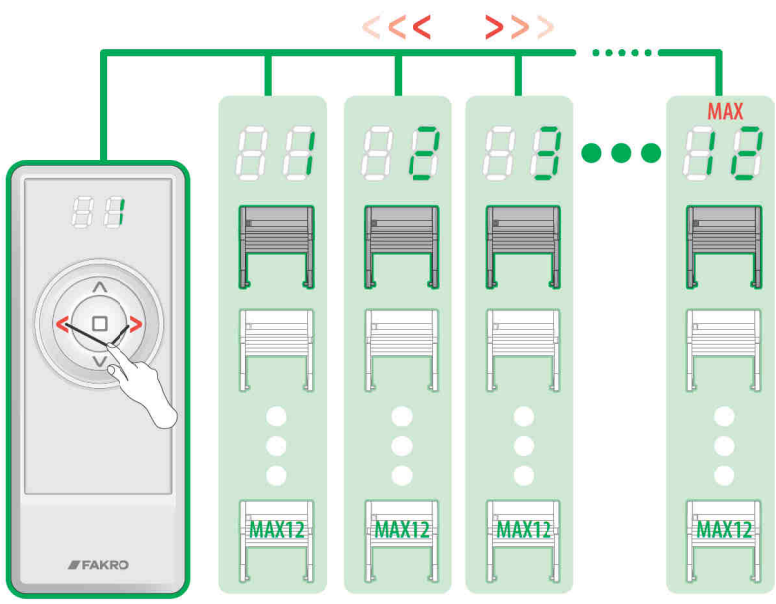

4b

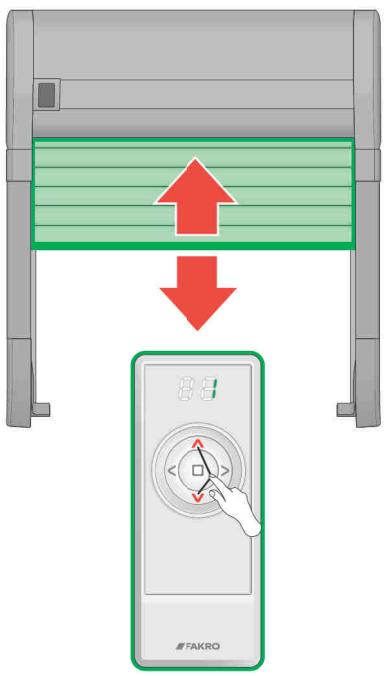

4c

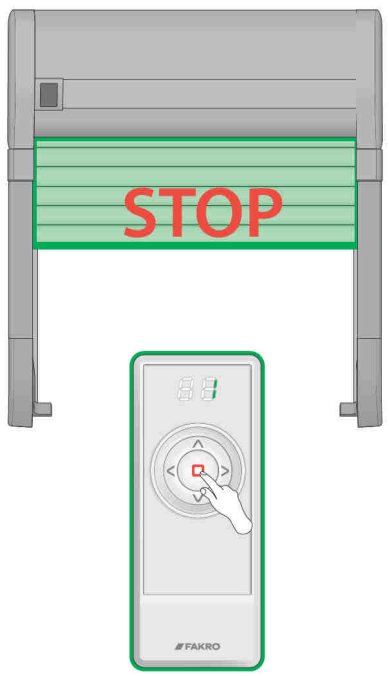

2\*

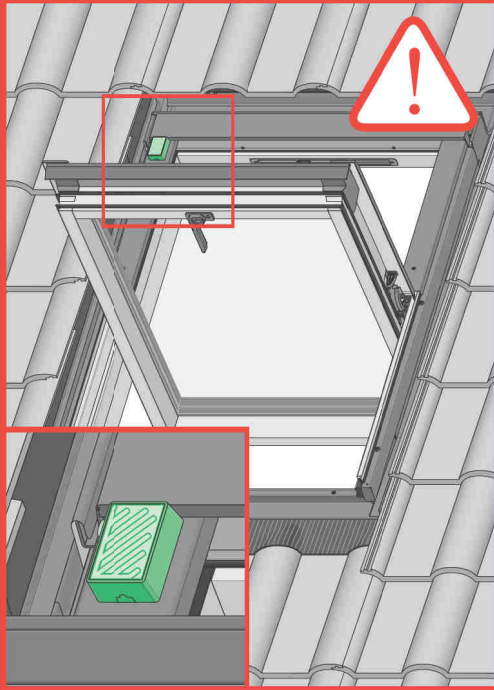

2a

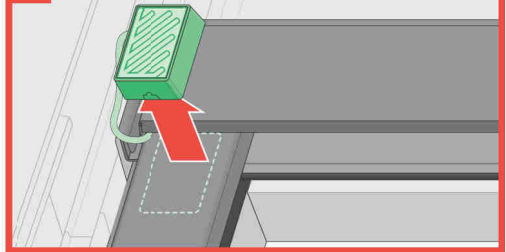

2b

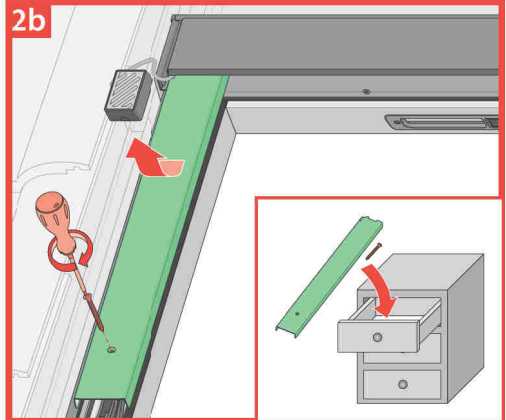

2c

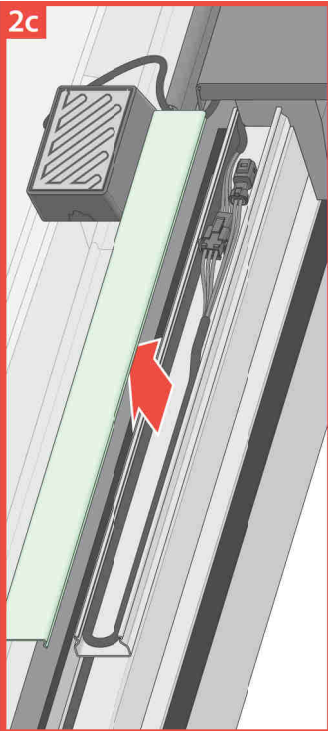

2d

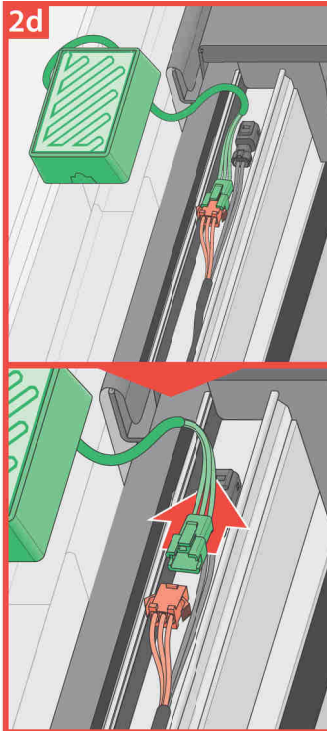

2e

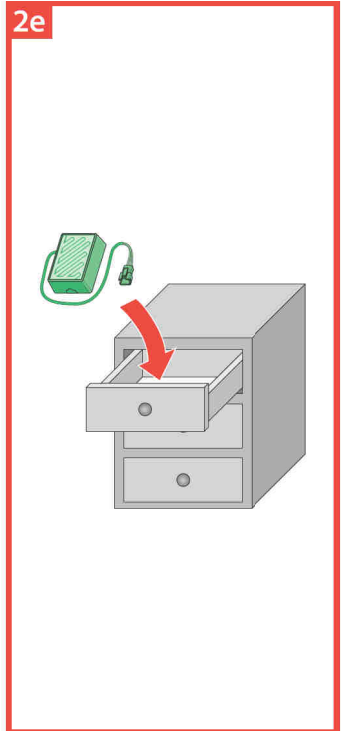

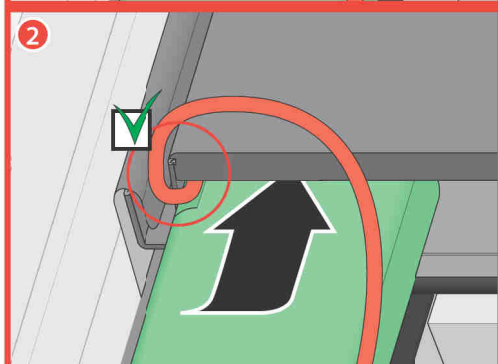
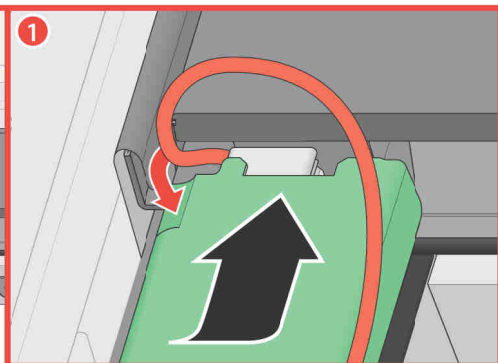
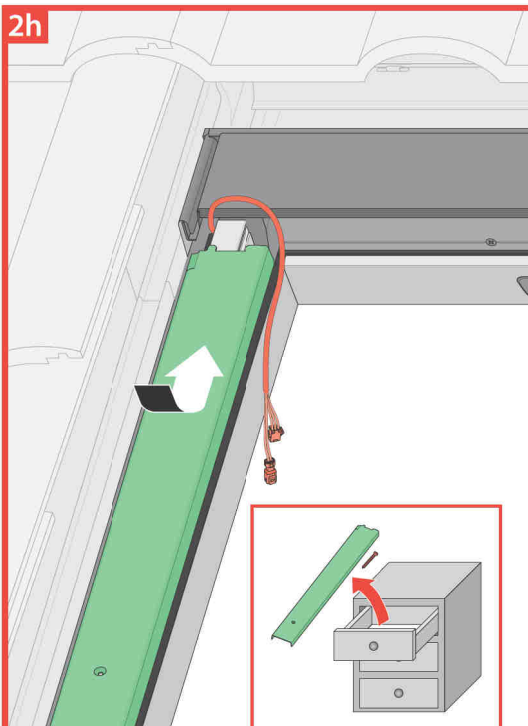
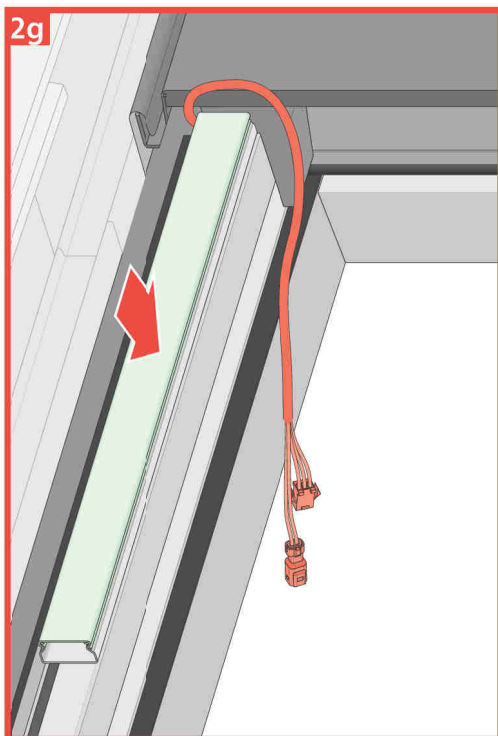
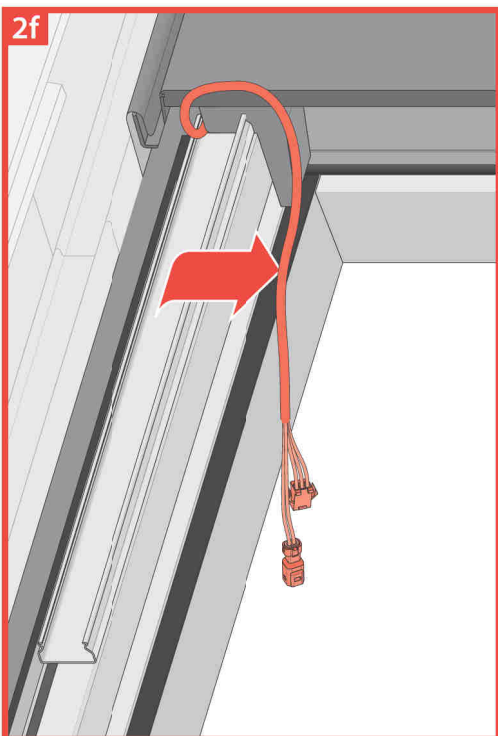

2i

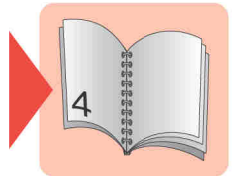
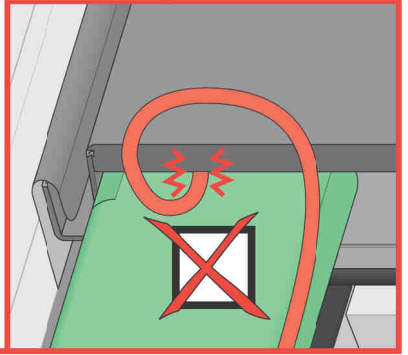
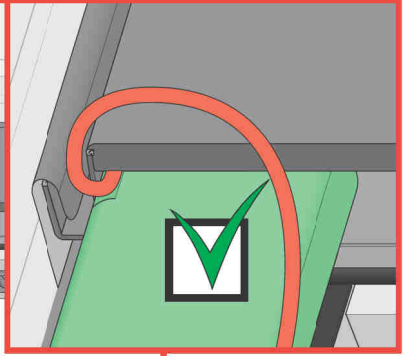
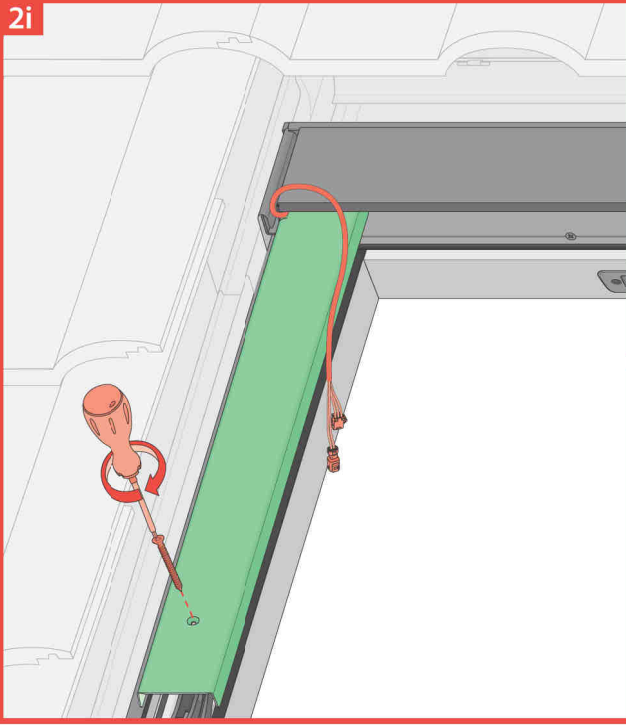

11\*

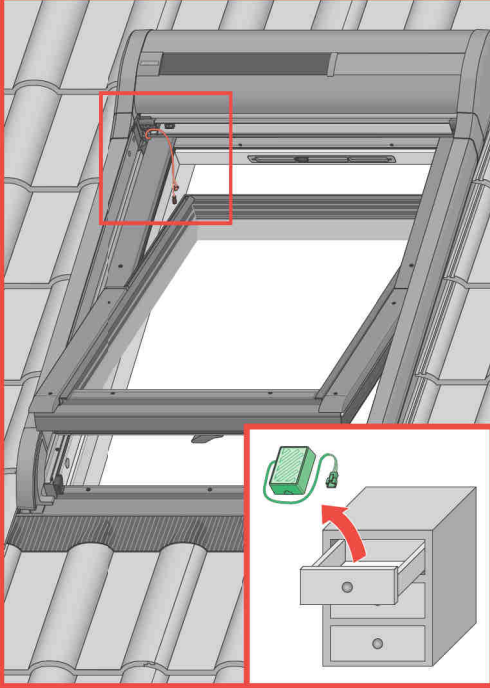

11a

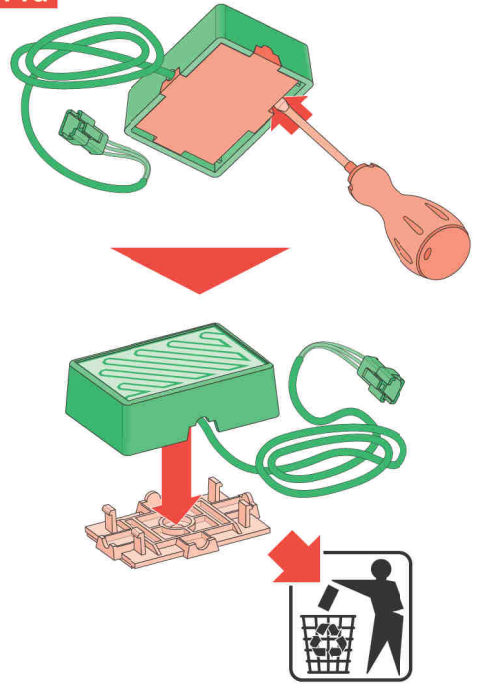

11b

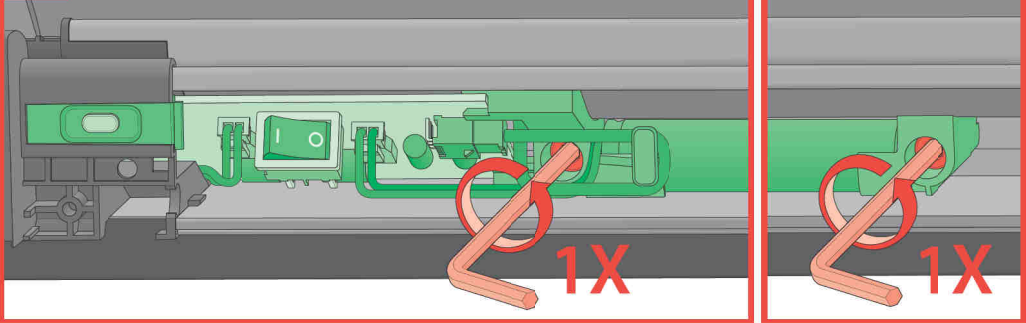

11c

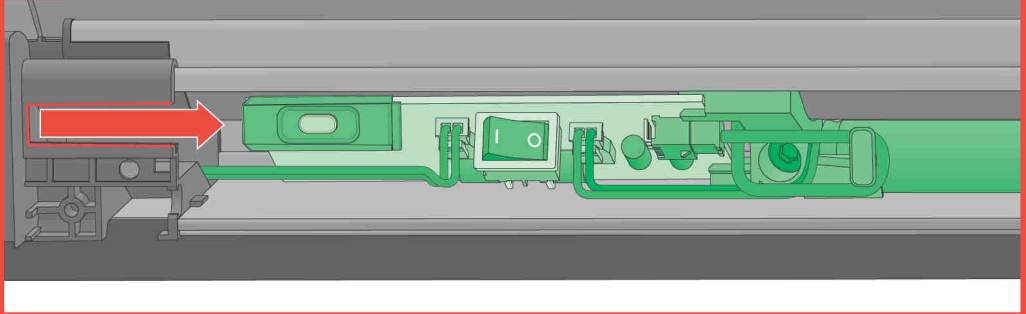

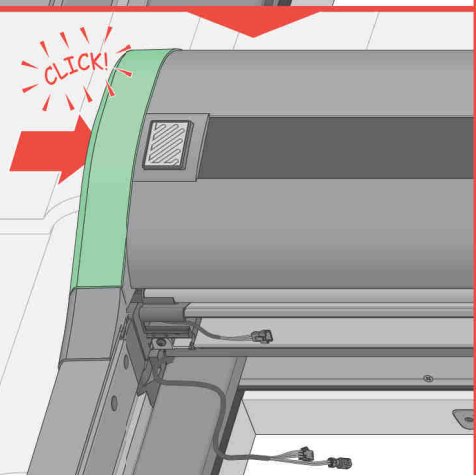
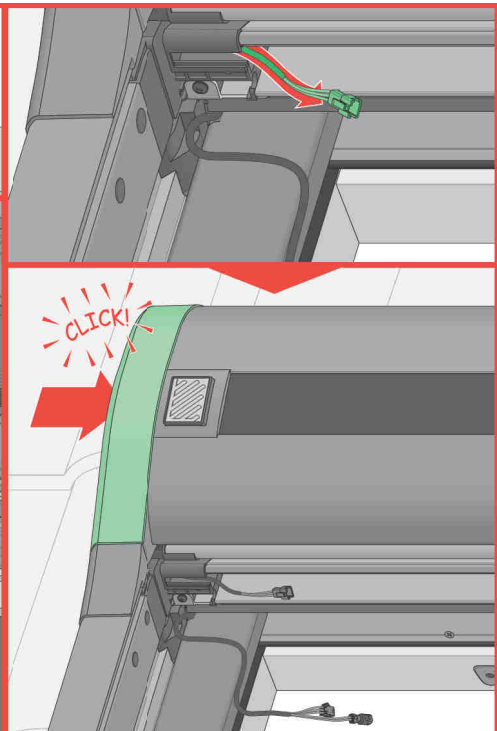
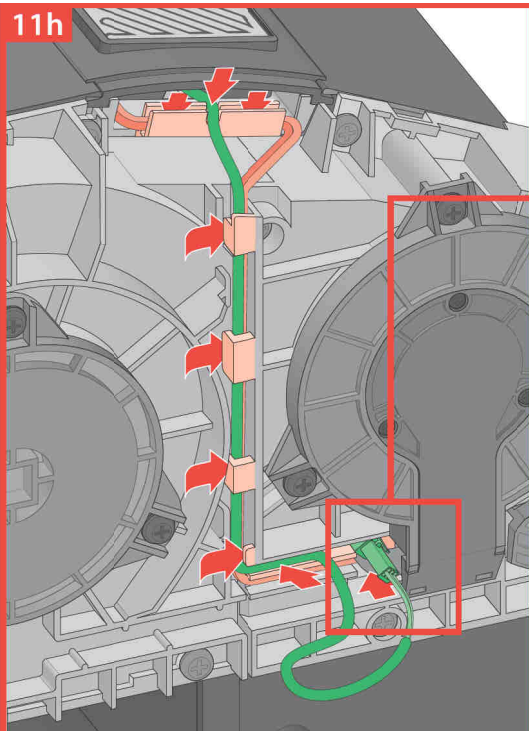
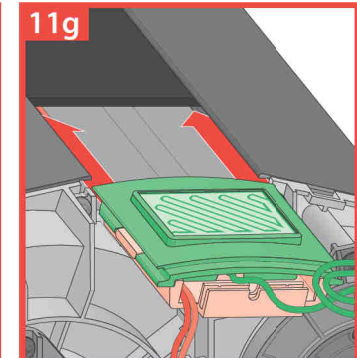
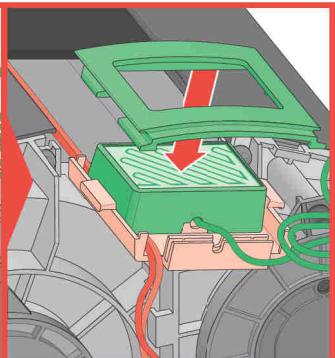
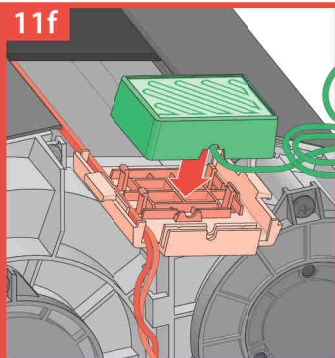
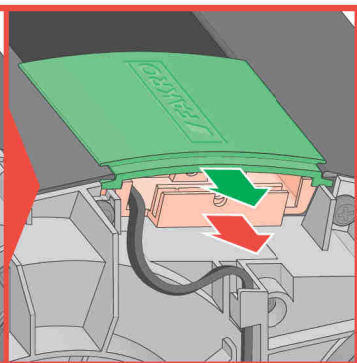
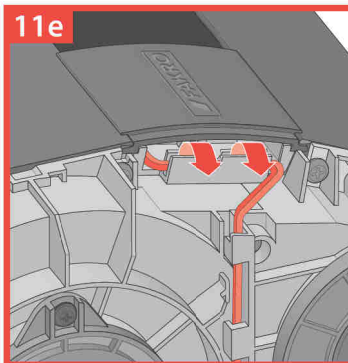
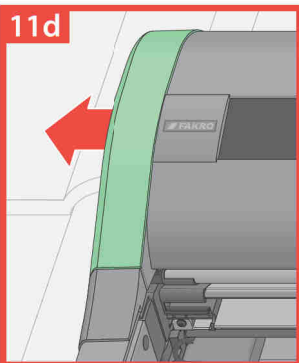

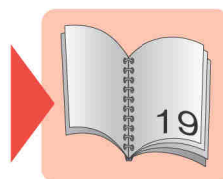
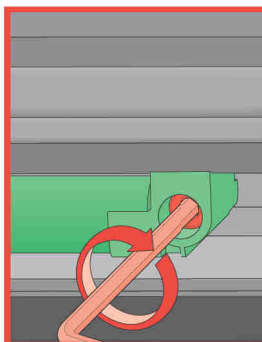
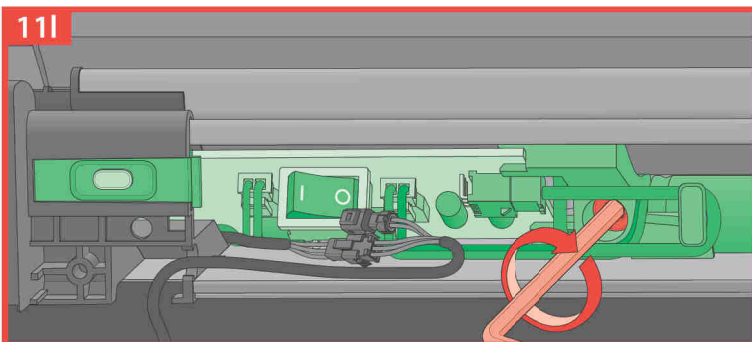
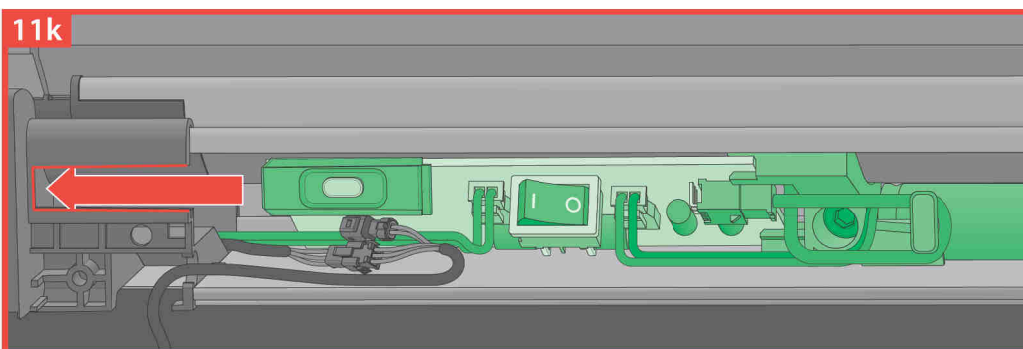
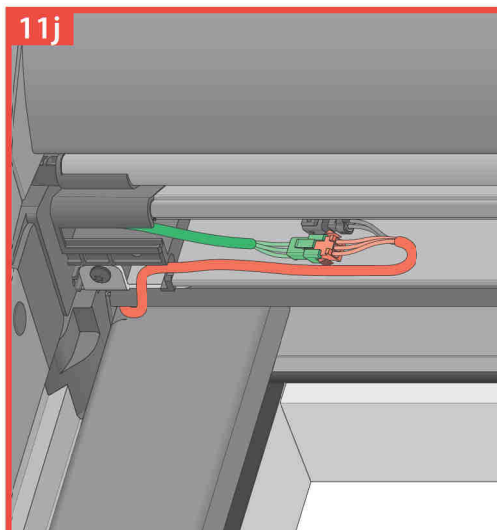
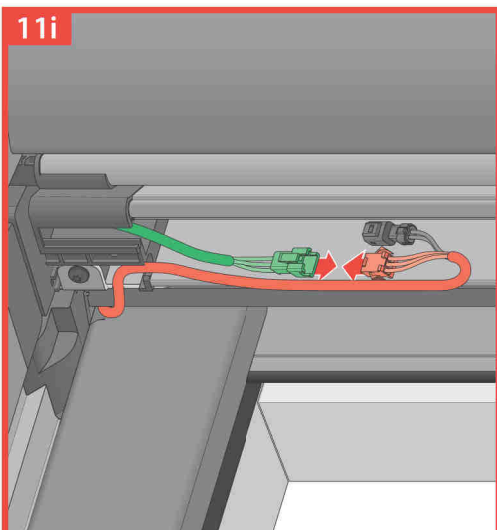

FTT

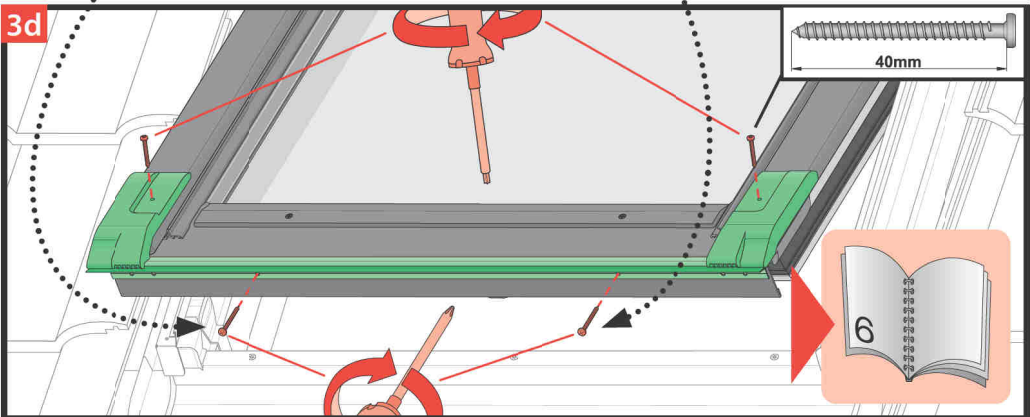
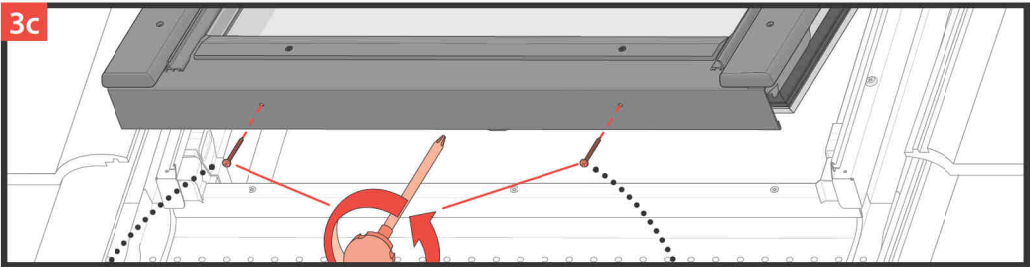
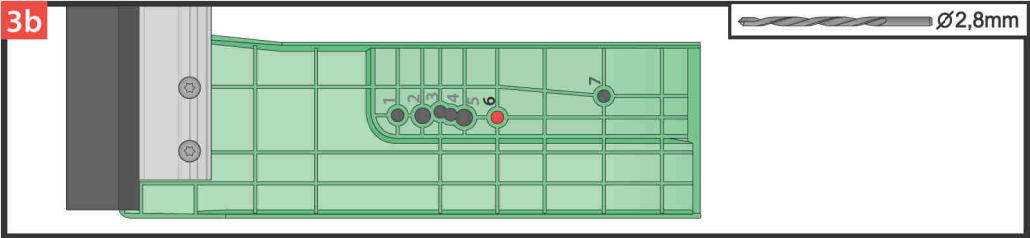
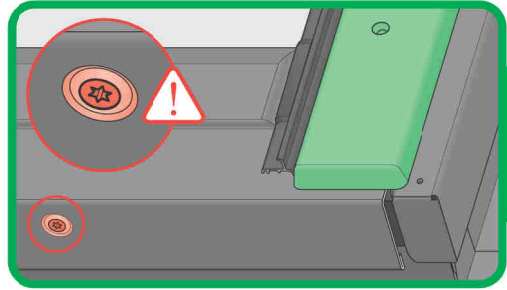
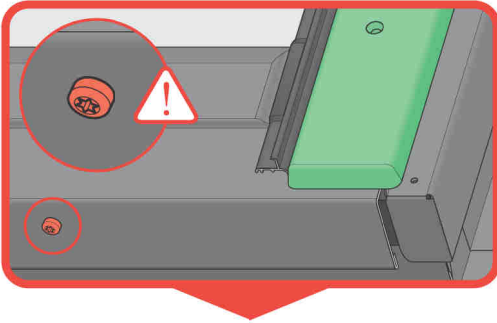
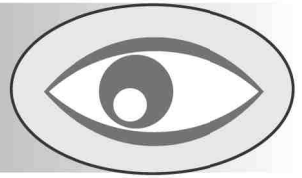

3b

Ø2,8mm

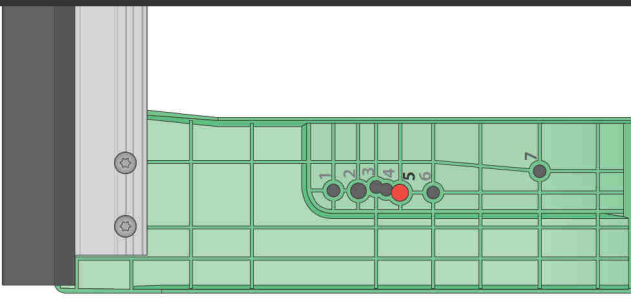

3c

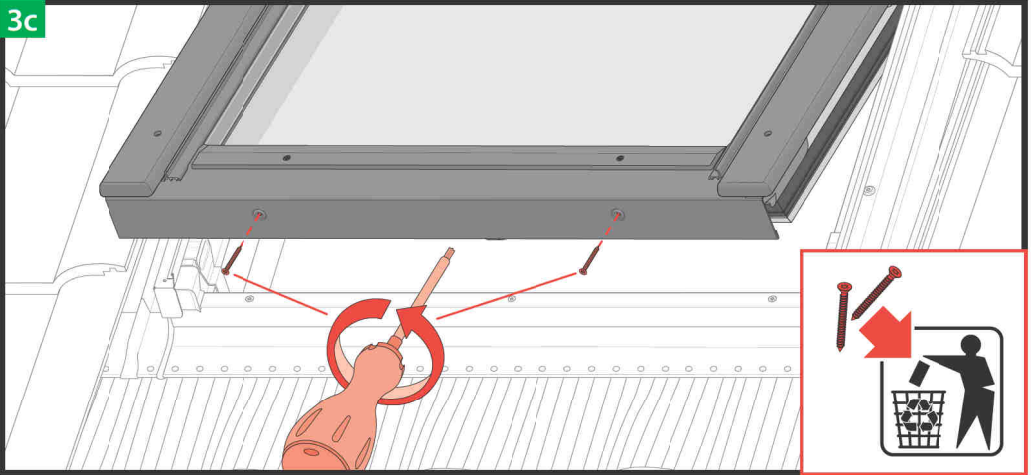

3d

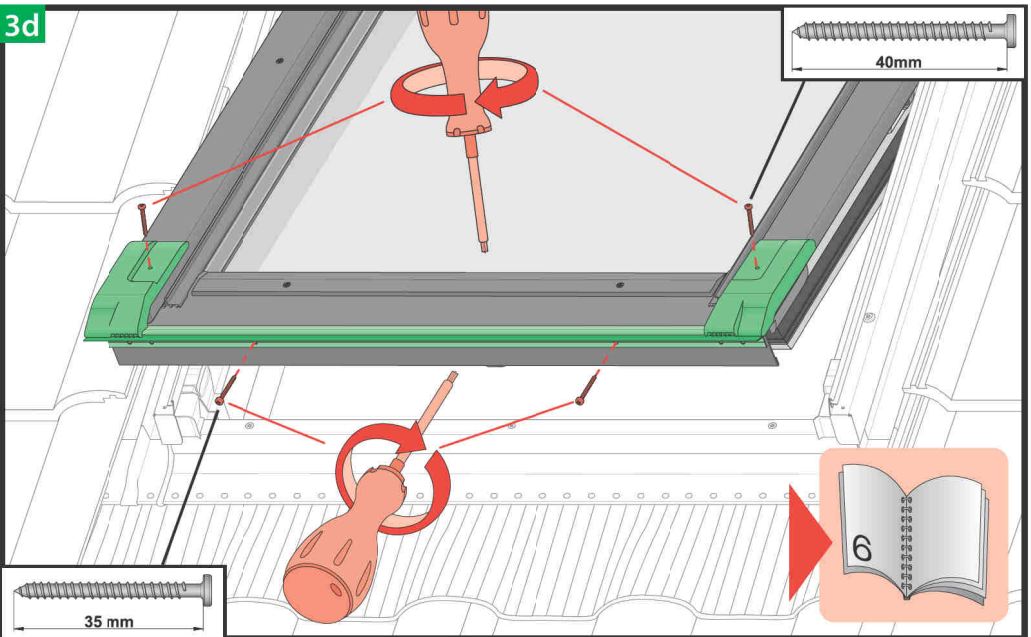

22495L0

22494L0

22495A0

22494A0

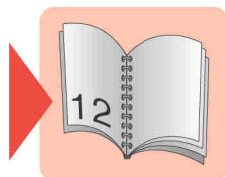
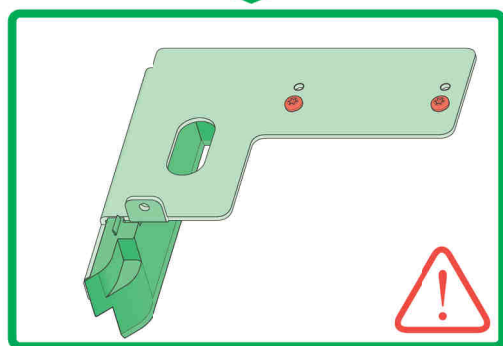
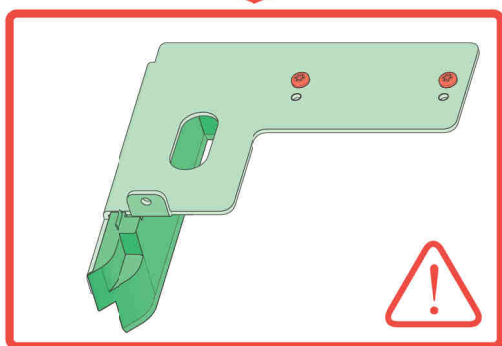
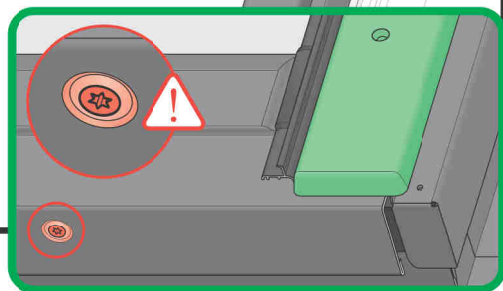
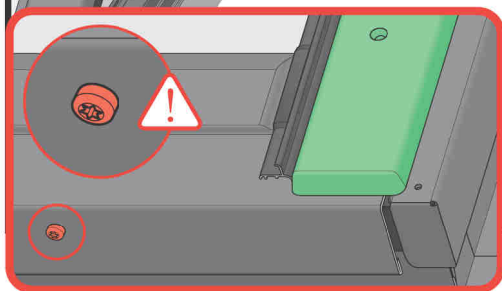
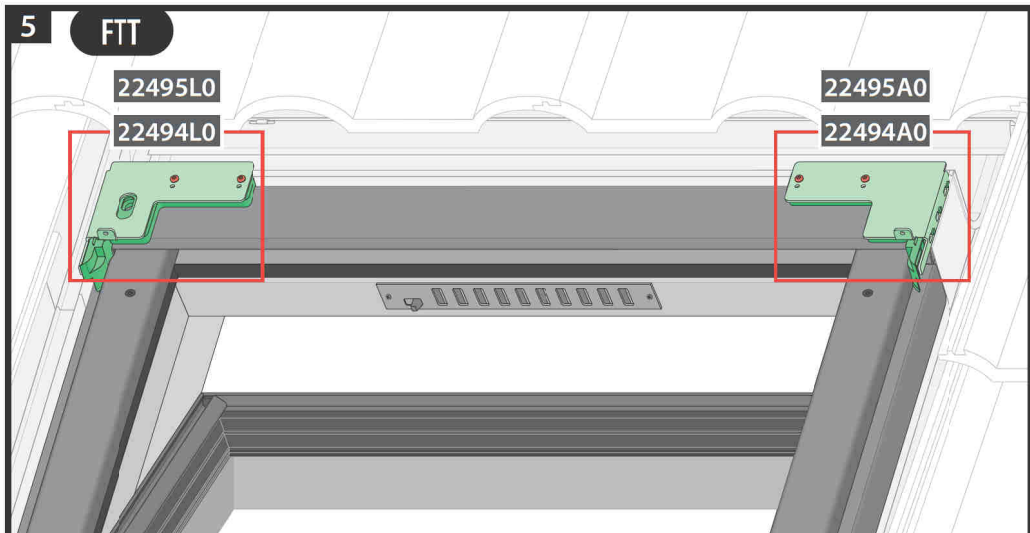



EN	Before installation, it is compulsory to read the NC9UM „ORIGINAL INSTRUCTIONS 2/3 Installation and user manual”.
1	Remove the cover strip from the battery compartment.
2	Open the window.
2*	In the case of electrically operated window perform additional operations.
3a	Remove screws positioned in the bottom part of the window sash.
3b	Make a hole in the bottom holder of the shutter in the place depending on the window type.
3c	Install the assembly unit holder.
3d	Screw the profile to the window sash having previously drilled the holes.
4, 4a, 4b, 4c	Use mounting washers to make holes in the window hood.
5, 5a, 5b, 5c	Install the mounting plate unit by selecting elements depending on the cladding type.
6a, 6b, 6c, 6d	Install assembly profiles of the shutter.
7	Slide the shutter onto holders and fix it.
8	Slide the side guide rail into the shutter casing and fix it with two screws.
9	Connect the opening restrictor with the shutter guide rail.
10	Repeat steps 8-9 for the left guide rail.
11	In the case of electrically operated window perform additional operations.
12	Install covering elements in the shutter cassette. Run the shutter.
13	Operate the shutter using the remote control. Do not run the shutter with the window open.
14	If necessary, adjust the shutter's end positions: open the window, press the button 5 times on the shutter's controller and then close the window. The shutter will automatically perform the end position calibration procedure.
15	Do not allow accumulation of snow on the shutter. For this purpose it is recommended to use devices preventing snow from sliding onto the shutter. Regularly remove any dirt that might obstruct operation of the shutter.

PL	Przed montażem należy zapoznać się z treścią instrukcji NC9UM „INSTRUKCJA ORYGINALNA 2/3 Zasady montażu i użytkowania”.
1	Zdemontować listwę maskującą z komory baterii.
2	Otworzyć okno.
2*	W przypadku okna elektrycznego wykonać dodatkowe czynności.
3a	Wykręcić wkręty znajdujące się w dolnej części skrzydła okna.
3b	Wykonać otwór w uchwycie dolnym rolety w miejscu uzależnionym od typu okna.
3c	Zamontować zespół uchwytu montażowego.
3d	Przykręcić profil do skrzydła okna wcześniej nawiercając otwory.
4, 4a, 4b, 4c	Użyć podkładek montażowych w celu wykonania otworów w kapturze okna.
5, 5a, 5b, 5c	Zamontować zespół blachy montażowej dobierając elementy w zależności od typu obłachowania.
6a, 6b, 6c, 6d	Zamontować profile montażowe rolety.
7	Nasunąć roletę na uchwyty, przykręcić.
8	Wsunąć prowadnicę boczną w korpus rolety i przykręcić za pomocą dwóch wkrętów.
9	Połączyć ogranicznik otwarcia z prowadnicą rolety.
10	Powtórzyć czynności 8-9 dla prowadnicy lewej.
11	W przypadku okna elektrycznego wykonać dodatkowe czynności.
12	Zamontować elementy maskujące w kasecie rolety. Uruchomić roletę.
13	Sterować roletą za pomocą pilota. Nie uruchamiać rolety przy otwartym oknie.
14	W razie potrzeby przeprowadzić regulację pozycji końcowych rolety: otworzyć okno, wcisnąć 5 razy przycisk na sterowniku rolety, a następnie zamknąć okno. Roleta samoczynnie wykona procedurę kalibracji pozycji końcowych.
15	Nie dopuszczać do nagromadzenia śniegu na roletcie, w tym celu zaleca się stosowanie urządzeń zapobiegających zsuwaniu się śniegu na roletę. Regularnie usuwać zanieczyszczenia, które mogłyby utrudniać pracę rolety.



BG	Проводителите и Продавач не носят отговорност за неспазване на съответните закони, строителни норми и конвенции за безопасност от използването на продукта, архитекта, монтажника или собственика на сградата.
CZ	Výrobce ani prodejce nenesou žádnou odpovědnost za neudržení průběžných platných zákonů, stavebních předpisů a bezpečnostních požadavků uživatelem výrobku, architektem, montážním nebo vlastním údržbov.
DE	Hersteller und Verkäufer übernehmen keine Haftung für Nichtbeachtung entsprechender Rechts- und Bauvorschriften sowie Sicherheitsanforderungen seitens Produktbenutzer, Architekten, Monteure oder Gebäudebesitzer.
EE	Tootja ja müüja ei vastuta toote kasutamise, arhitekti, paigaldaja või hoone omaniku poolt kehtivate seaduste, määruste ja ohutusnõuete mittejärgimise eest.
ES	El fabricante y el vendedor no tienen ninguna responsabilidad por el incumplimiento de la ley vigente, normas de construcción y exigencias de seguridad por parte del usuario del producto, arquitecto, instalador o el propietario del edificio.
FR	Le fabricant et le vendeur ne prend aucune responsabilité de ne pas respecter les lois applicables, les règlements sur les bâtiments et les exigences de sécurité par l'utilisateur du produit, l'architecte, l'installateur ou le propriétaire du bâtiment.
GB	Manufacturer and Seller shall bear no liability for failure to comply with the applicable laws, building codes and safety requirements by the user of the product, architect, fitter or owner of the building.
HU	A gyártó és a forgalmazó nem vállal semmilyen felelősséget a vonatkozó törvényi, építési és biztonsági előírások nemtartásáért, építész, beépítőmester vagy épülettulajonos által be nem tartásáért.
IT	Il Produttore e il Venditore non potranno essere ritenuti responsabili per il mancato rispetto da parte dell'utente del prodotto, di progettista, dell'installatore o del proprietario dell'edificio, delle leggi vigenti, nonché dei regolamenti edilizi e di quelli relativi alla sicurezza.

LT	Gaminintojas ir pardavėjas neprisiima jokios atsakomybės už tai, kad gamintojas, naudotojas, architektas, montuotojas ar pastato savininkas nesilaiko galiojančių statybos, statybos ir saugos reikalavimų.
LV	Rakstājs un mānītājs neņem atbildību par likumu, noteikumu un drošības prasību neievērošanu, no produkta lietotāja, arhitekta, uzstādītāja vai ekspluatējoša puses.
NL	De fabrikant en verkoper zijn niet aansprakelijk voor gevolgen bij het niet opvolgen van toepasselijke wetten, bouwbesluiten en veiligheidsvoorschriften door de gebruiker van het product, de architect, de installateur of de eigenaar van het gebouw.
PL	Producent i Sprzedawca nie ponosi żadnej odpowiedzialności za nieprzestrzeganie stosownych przepisów prawa, przepisów budowlanych i wymogów bezpieczeństwa przez użytkownika produktu, architekta, montażystę lub właściciela budynku.
PT	O fabricante e o vendedor não têm nenhuma responsabilidade pelo o não cumprimento da lei, códigos de construção e as exigências de segurança por parte do usuário do produto, arquiteto, instalador ou proprietário do edifício.
RO	Nici producătorul, nici distribuitorul nu își vor asuma răspunderea de a răspunde pentru neapăsarearea legilor în vigoare, a legilor din domeniul construcțiilor sau a măsurilor de siguranță impuse utilizării produsului, arhitectului, montajului sau proprietarilor clădirii.
RU	В случае несоблюдения армией строим, монтажником или владельцем здания строительных правил и норм безопасности ответственность с производителя и продавца снимается.
SI	Proizvajalec in prodajalec ne prejemata odgovornosti za neupoštevanje ustreznih pravnih in gradbenih predpisov ter varnostnih zahtev s strani uporabnika izdelka, projektanta, montažerja ali lastnika objekta.
SK	Výrobca a predávateľ nenesú zodpovednosť za neudržanie průběžných platných zákonů, stavebních předpisů a bezpečnostních požadavků uživatelem výrobku, architektem, montážním nebo vlastním údržbov.