

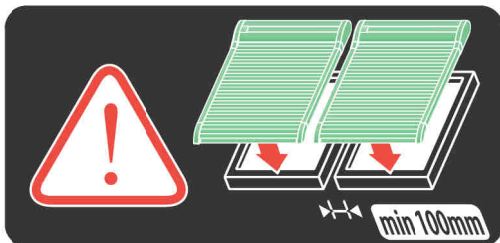

ARZ Komfort Z-Wave

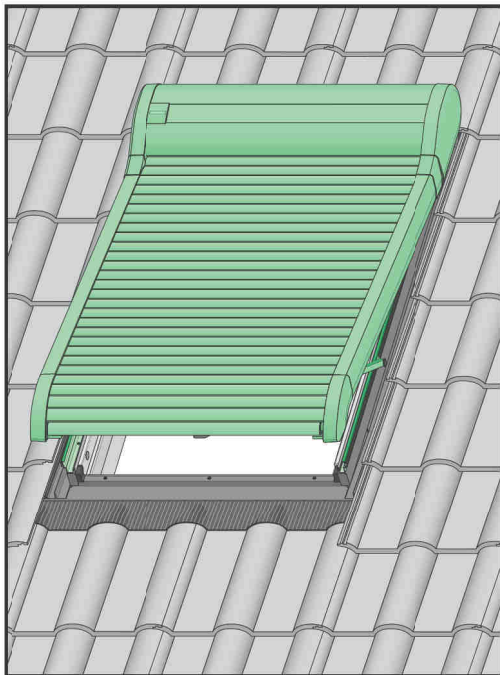

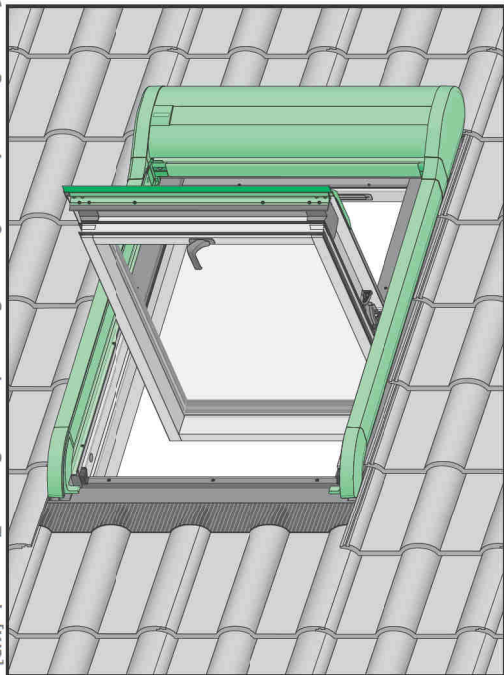

Ø10mm

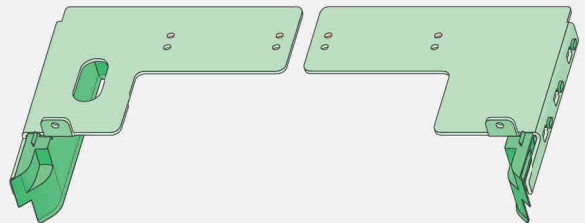
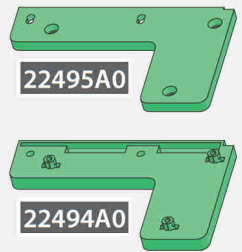
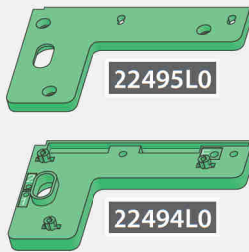
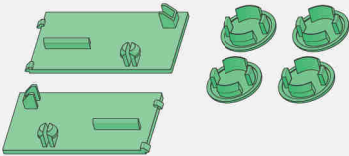
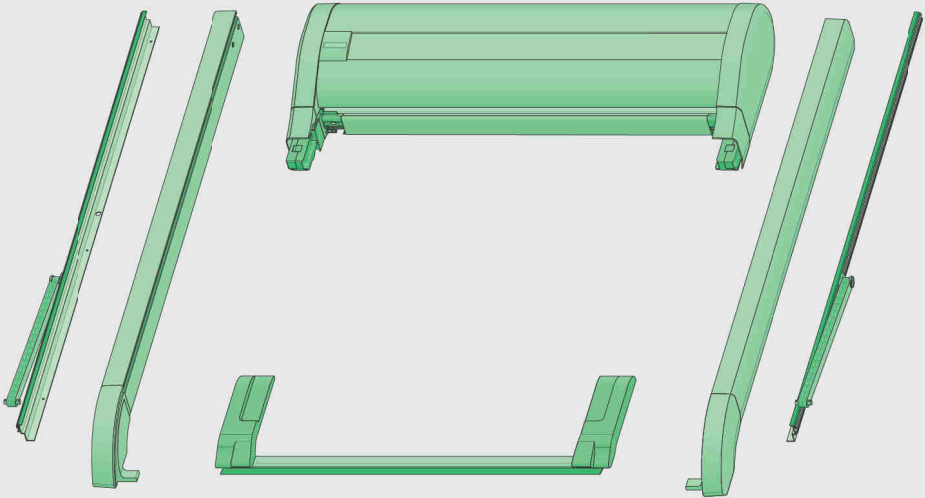

1

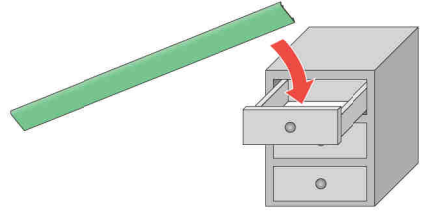
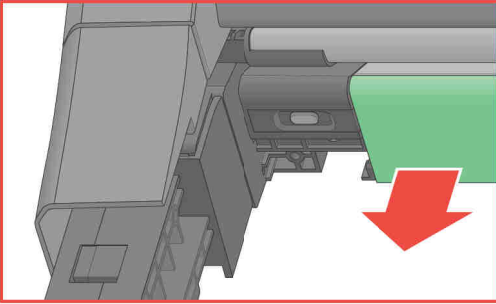
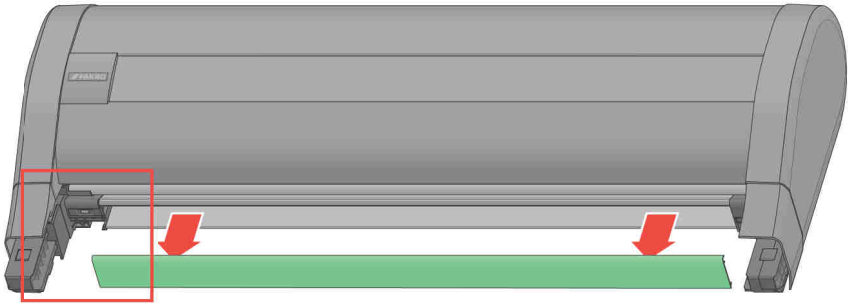

2

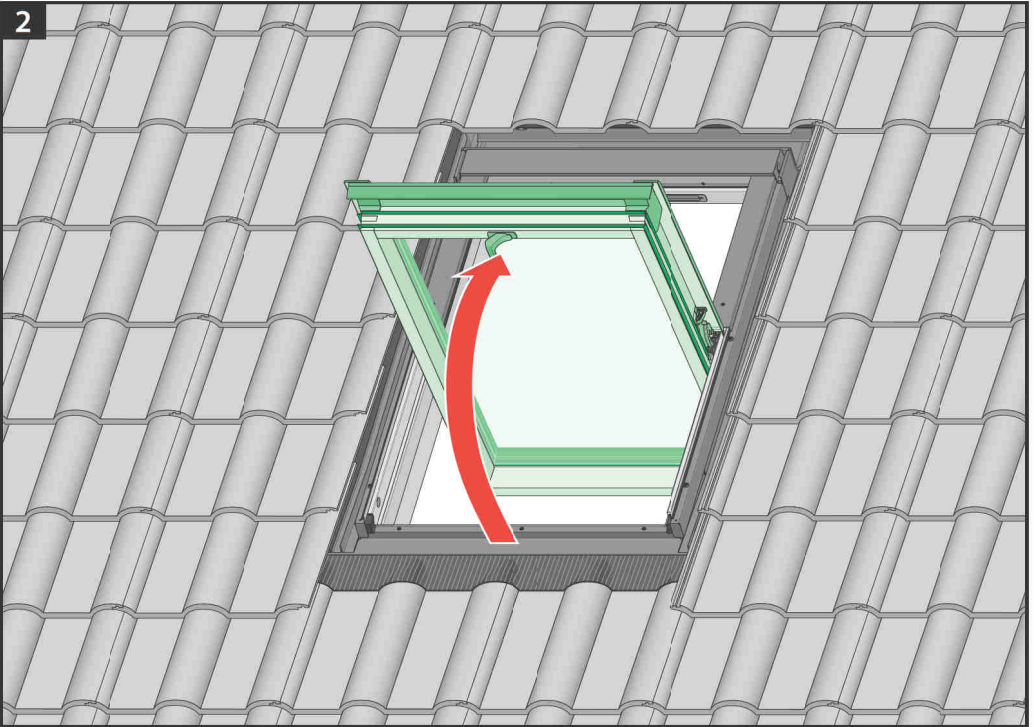

3

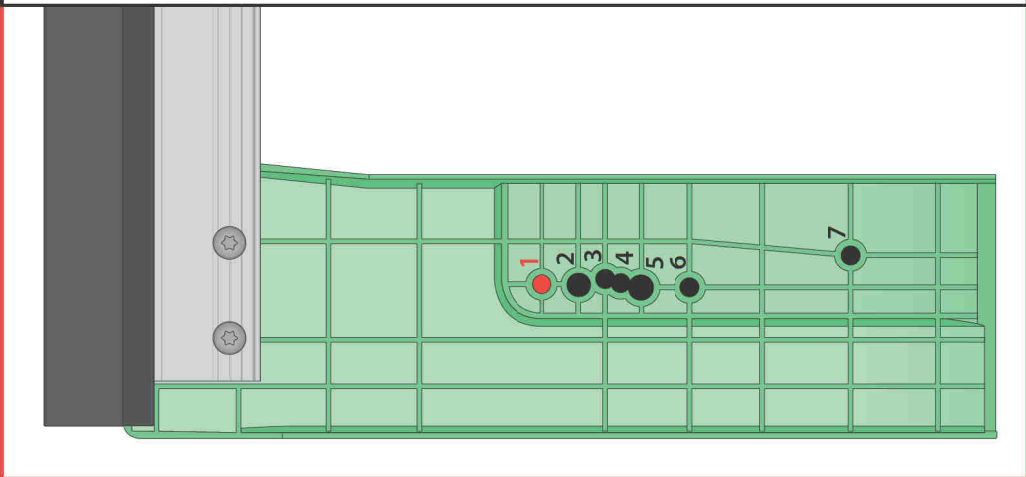
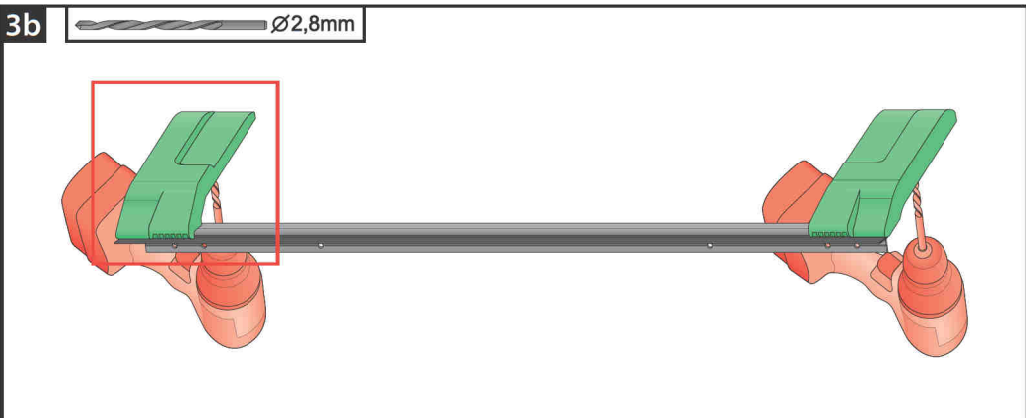
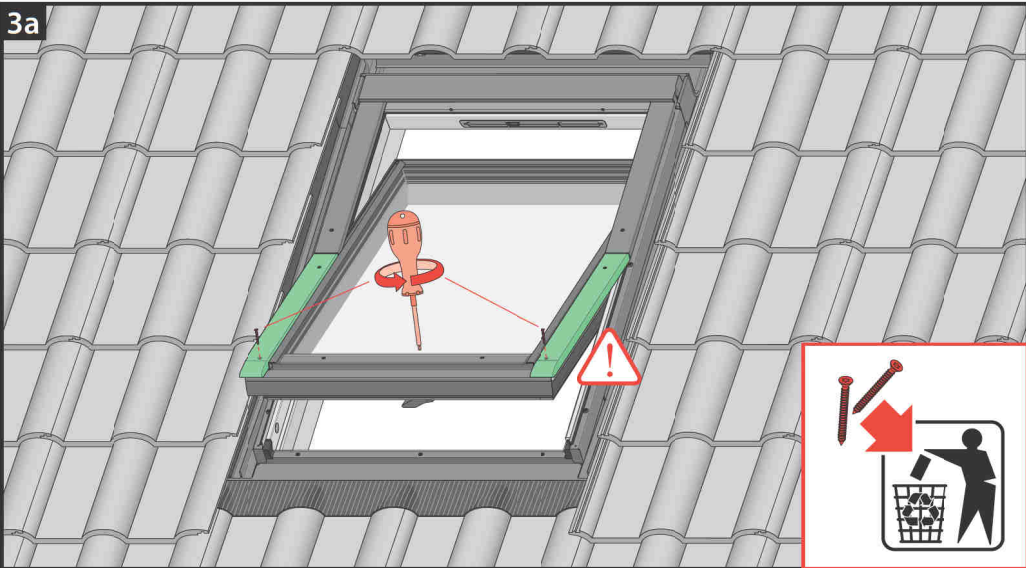

3c

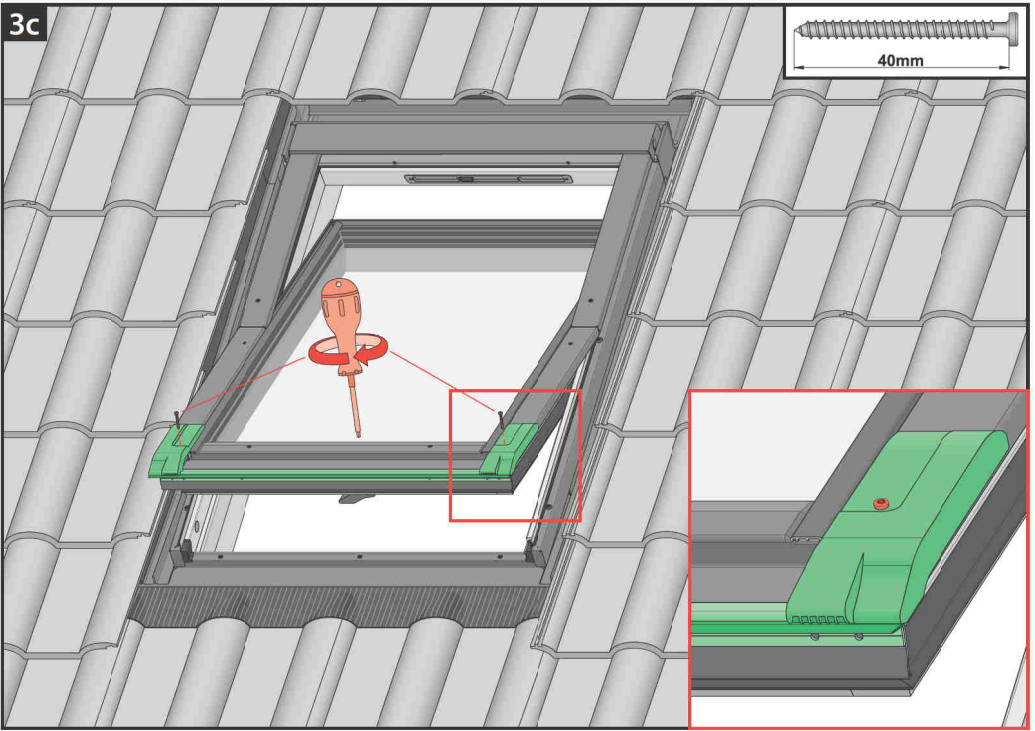
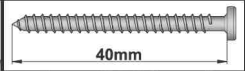

3d

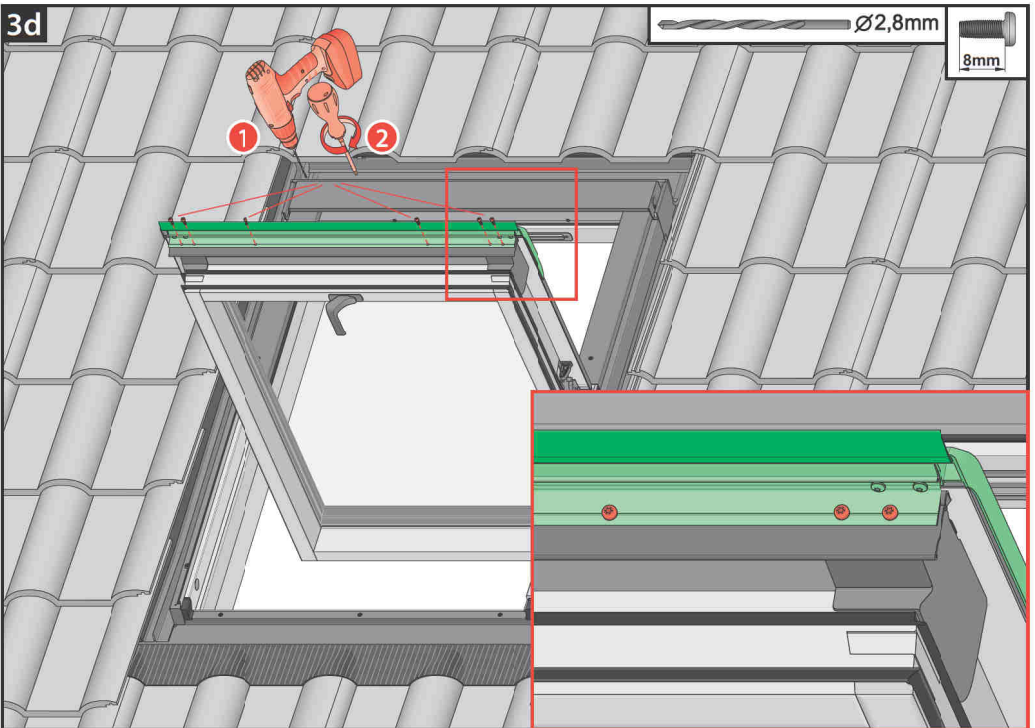
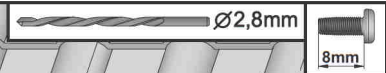

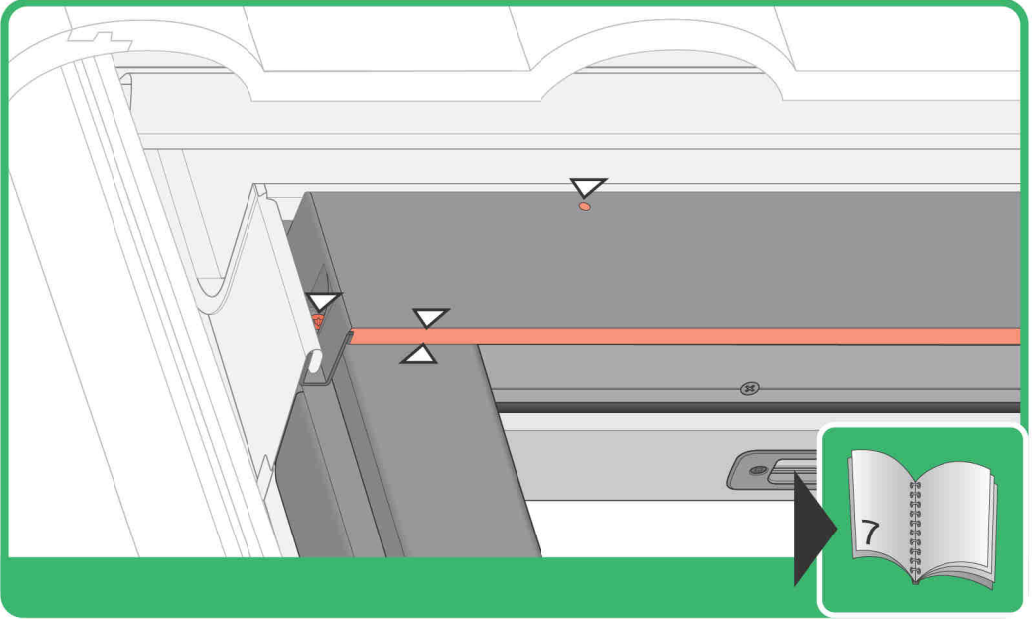
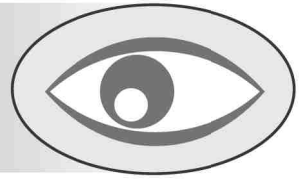

type Z-Wave

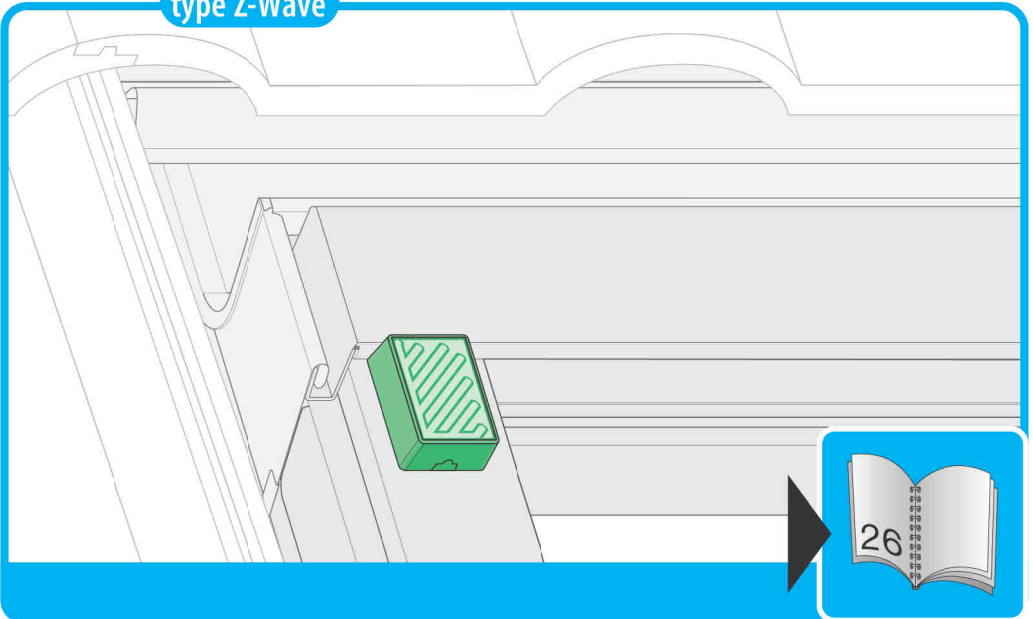

4a

$\varnothing 2,8\text{mm}$ $\varnothing 10\text{mm}$

MAX 5mm

22494L0

50 mm

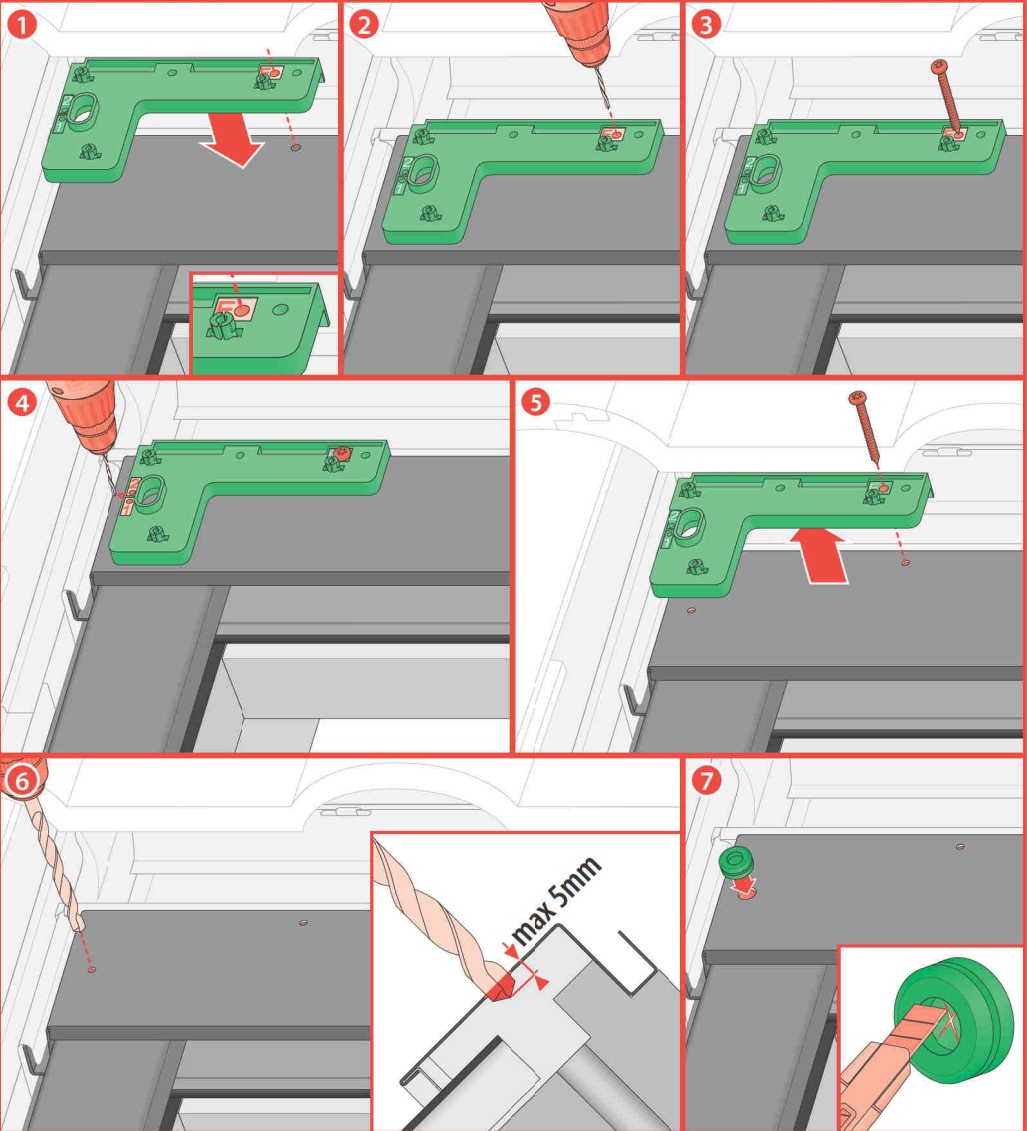

4b

Ø2,8mm

22494L0

22494A0

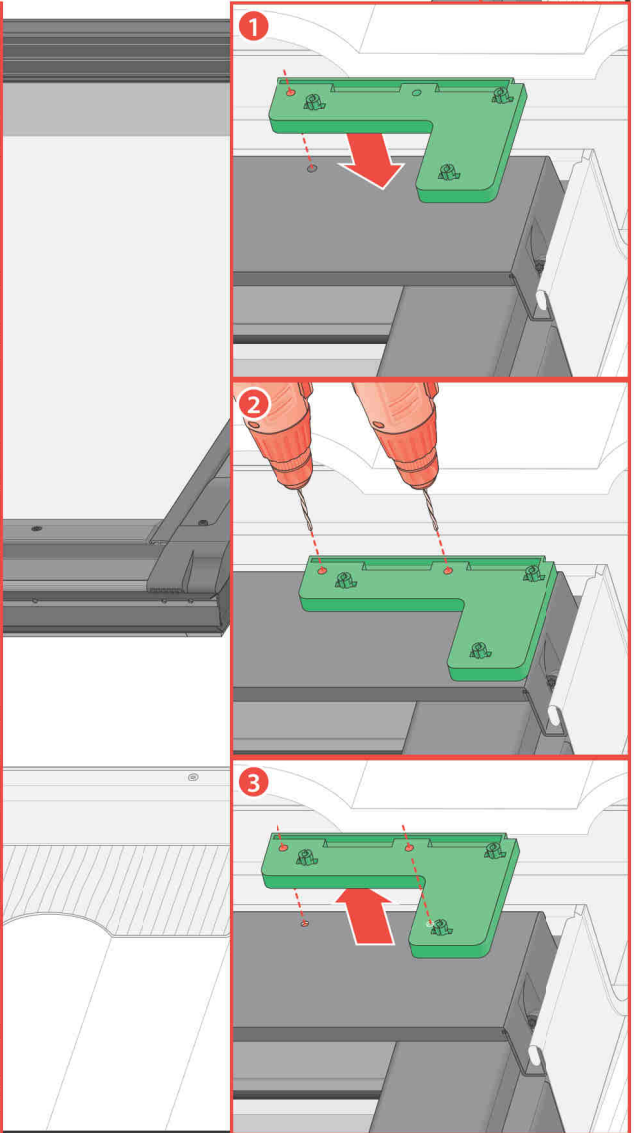
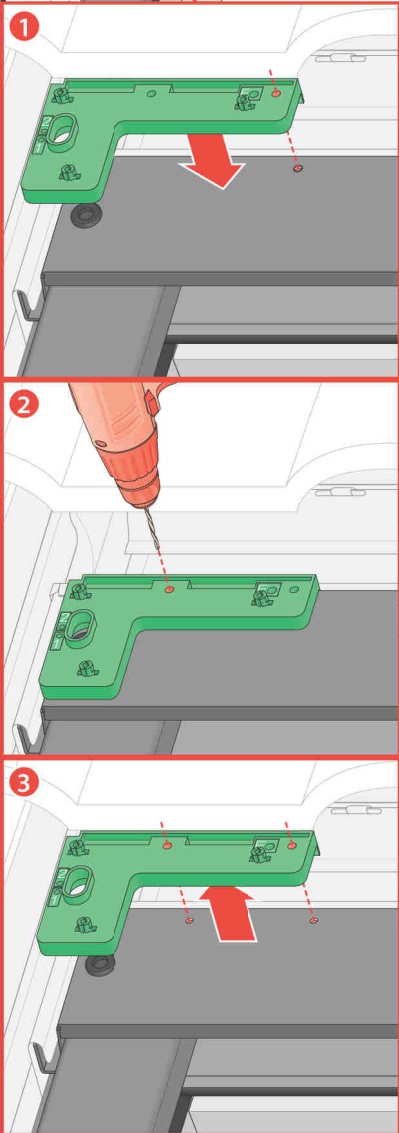

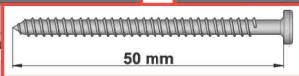
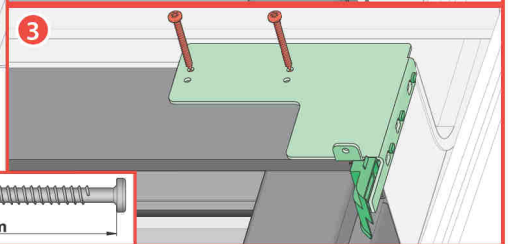
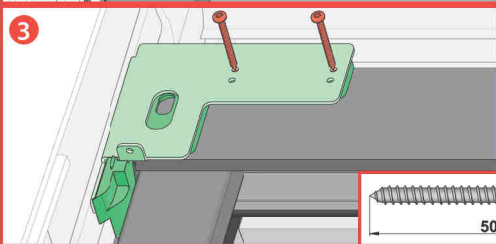
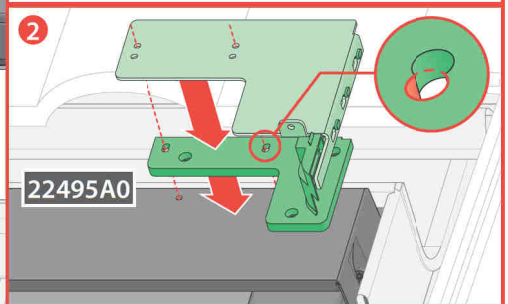
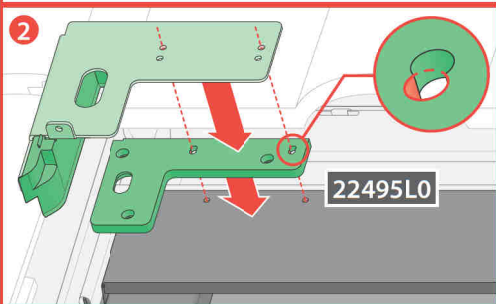
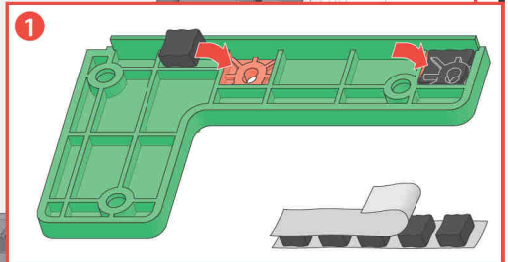
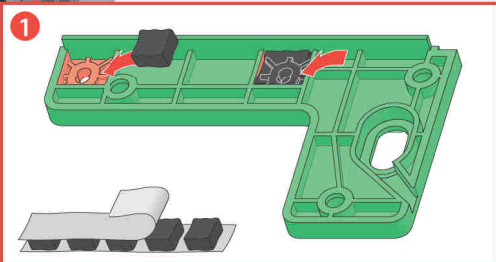
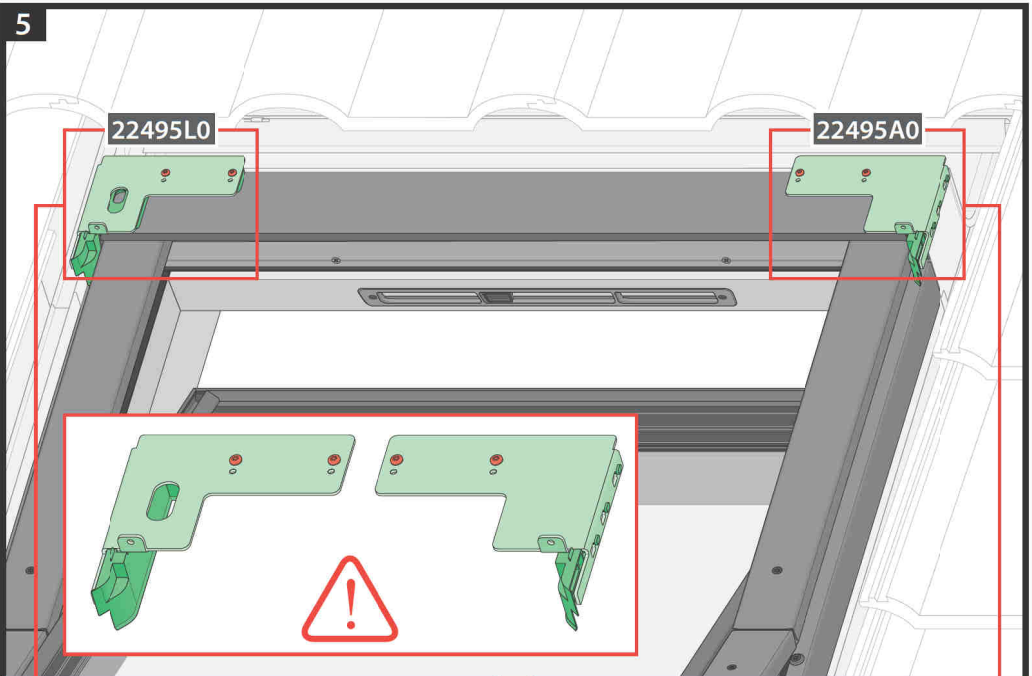

6a

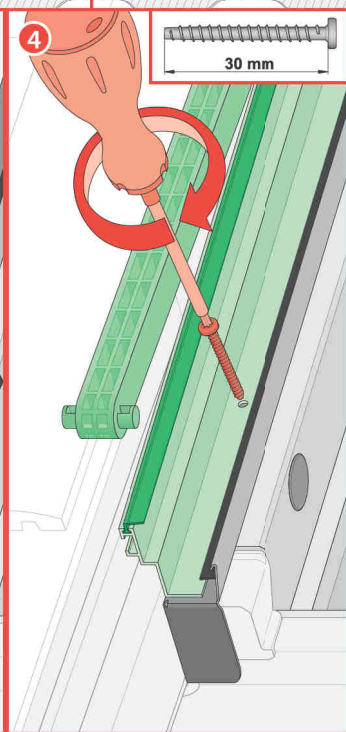
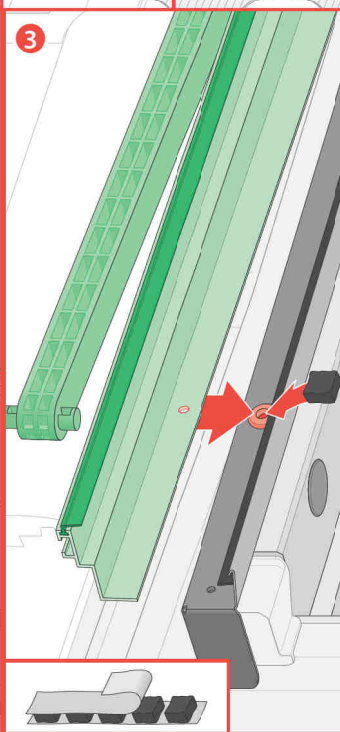
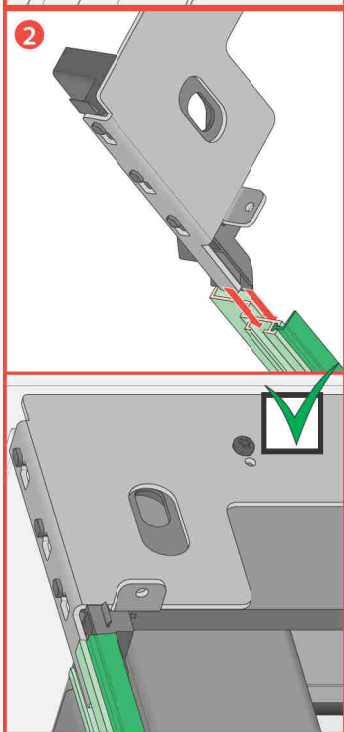
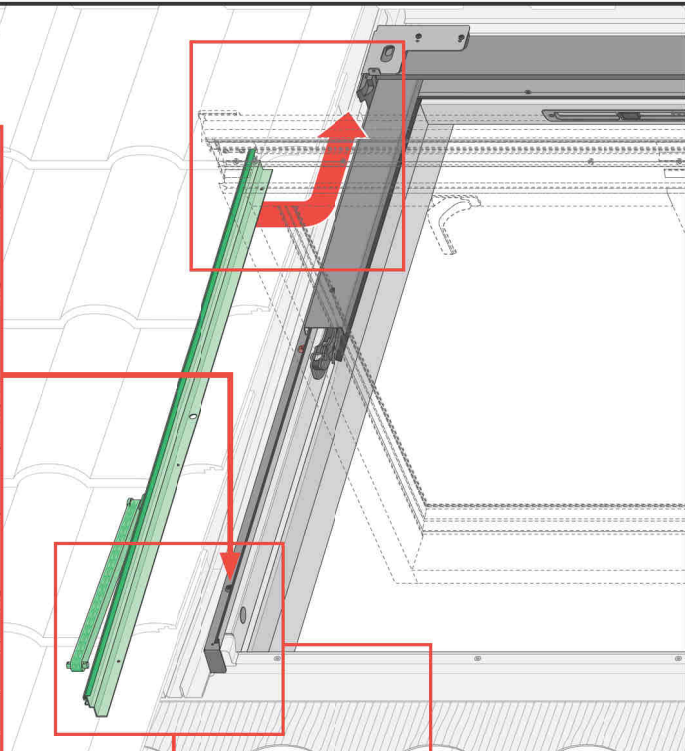
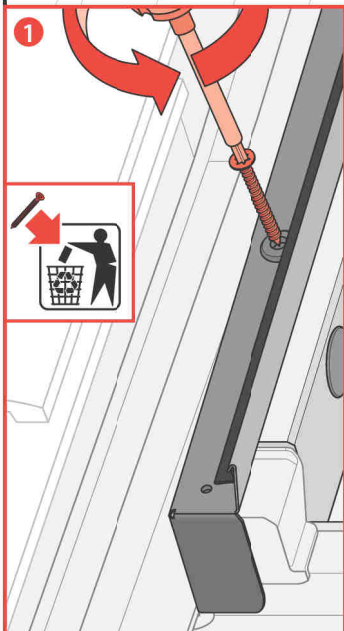

6b

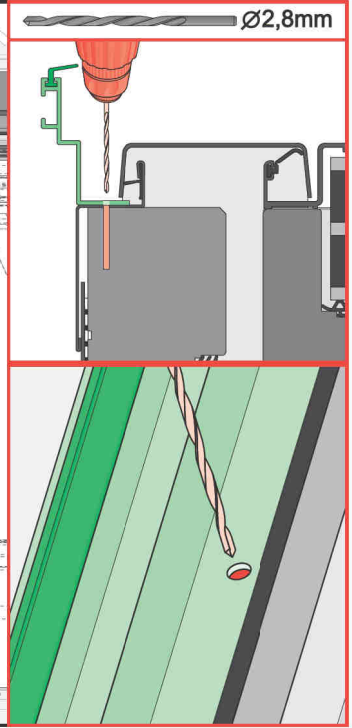
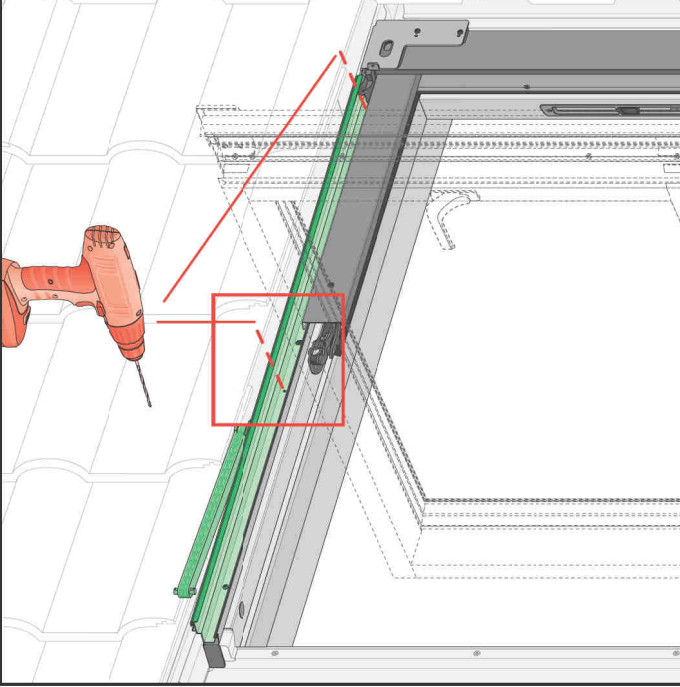

6b* | FPP MAX / PPP MAX

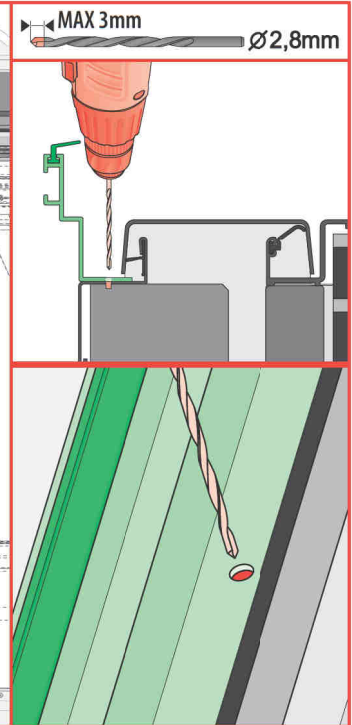
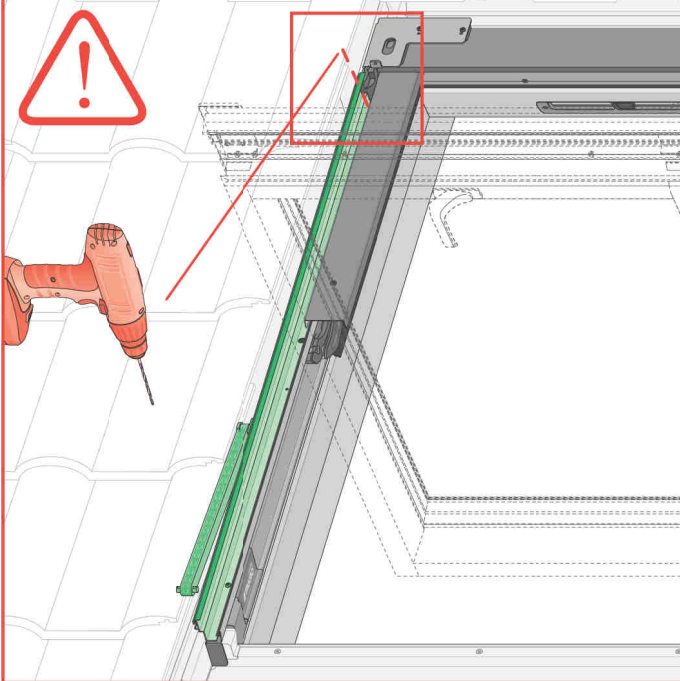

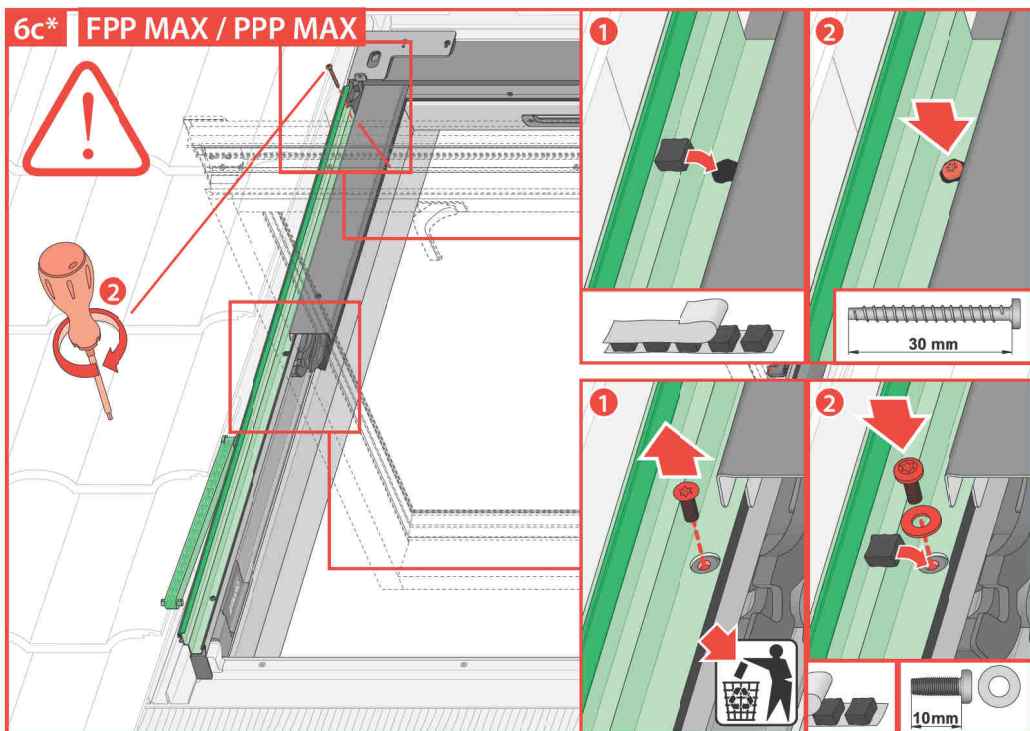
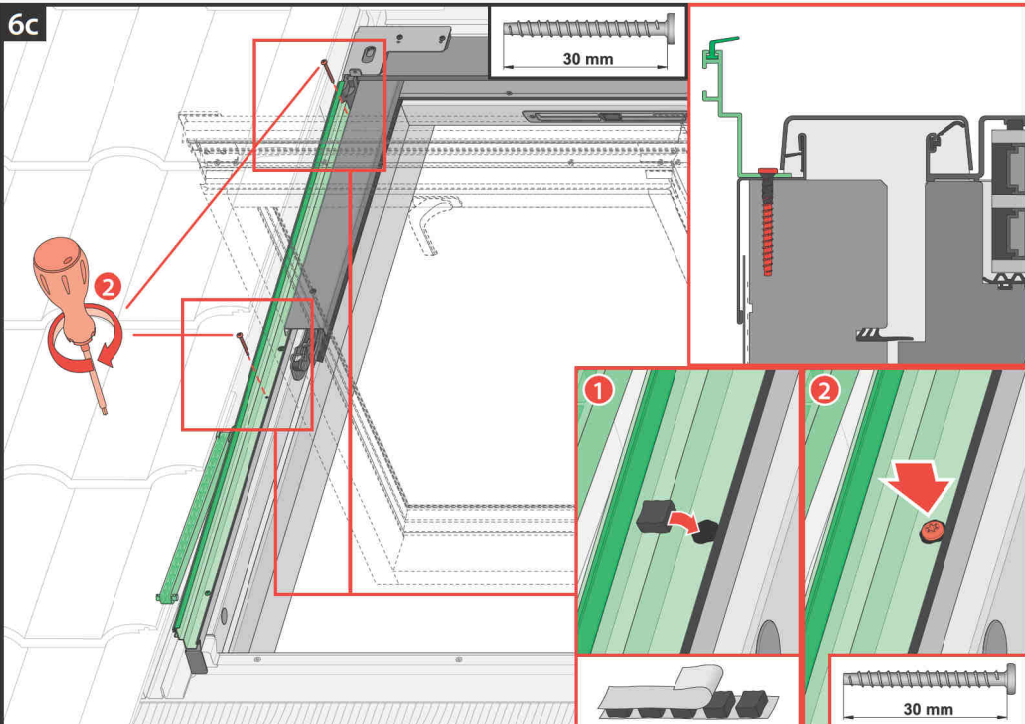

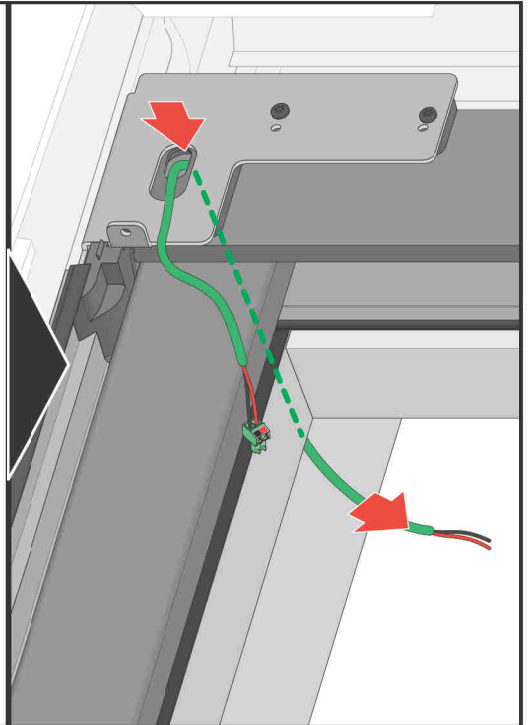
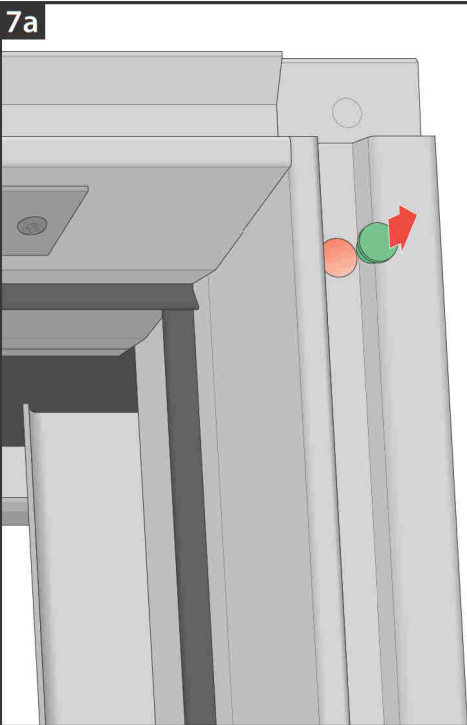
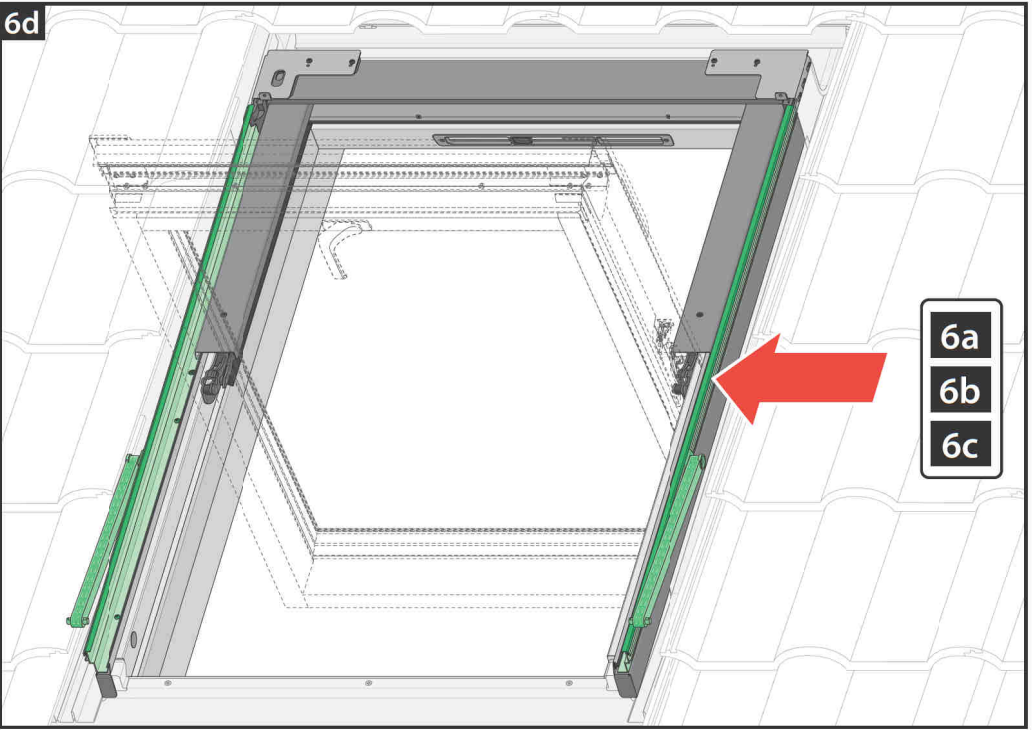

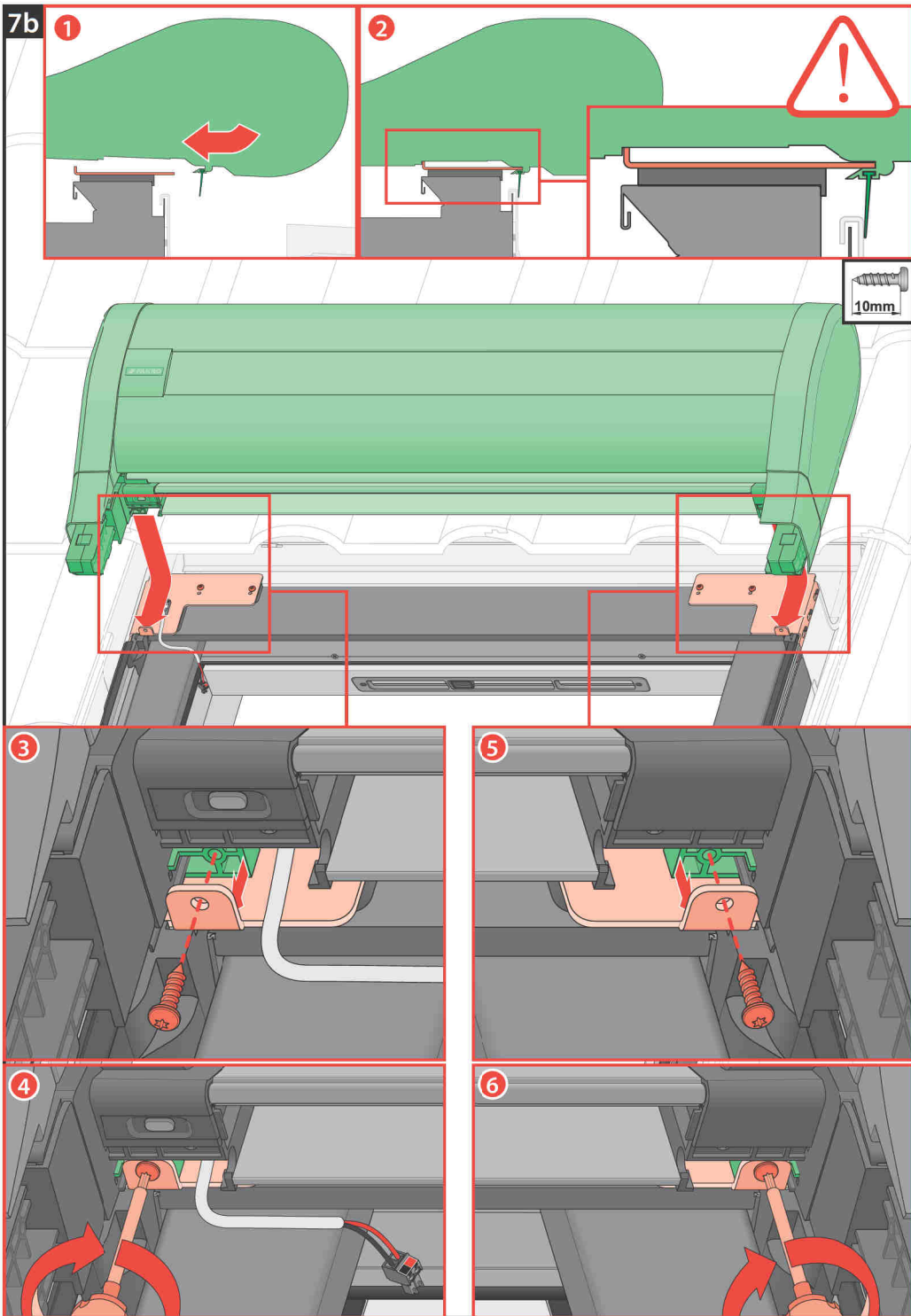

8

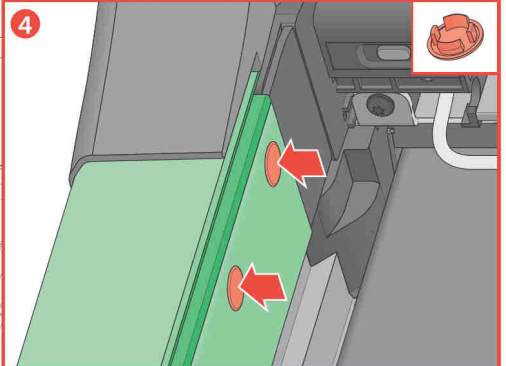
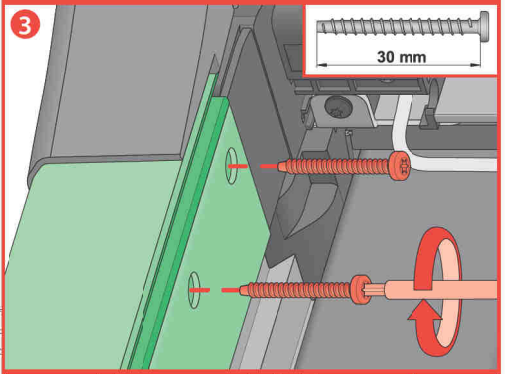
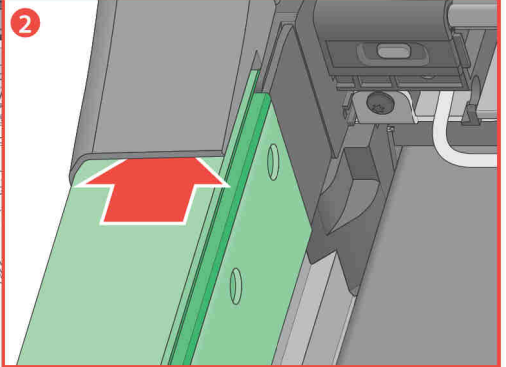
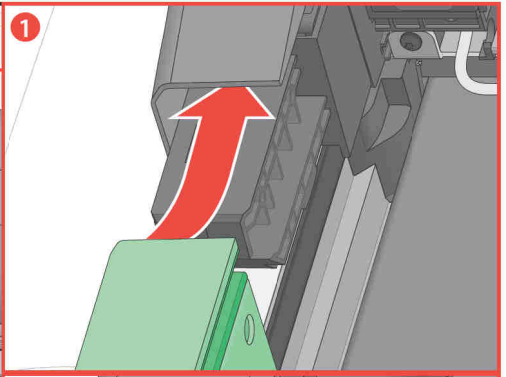

9

1

2

3

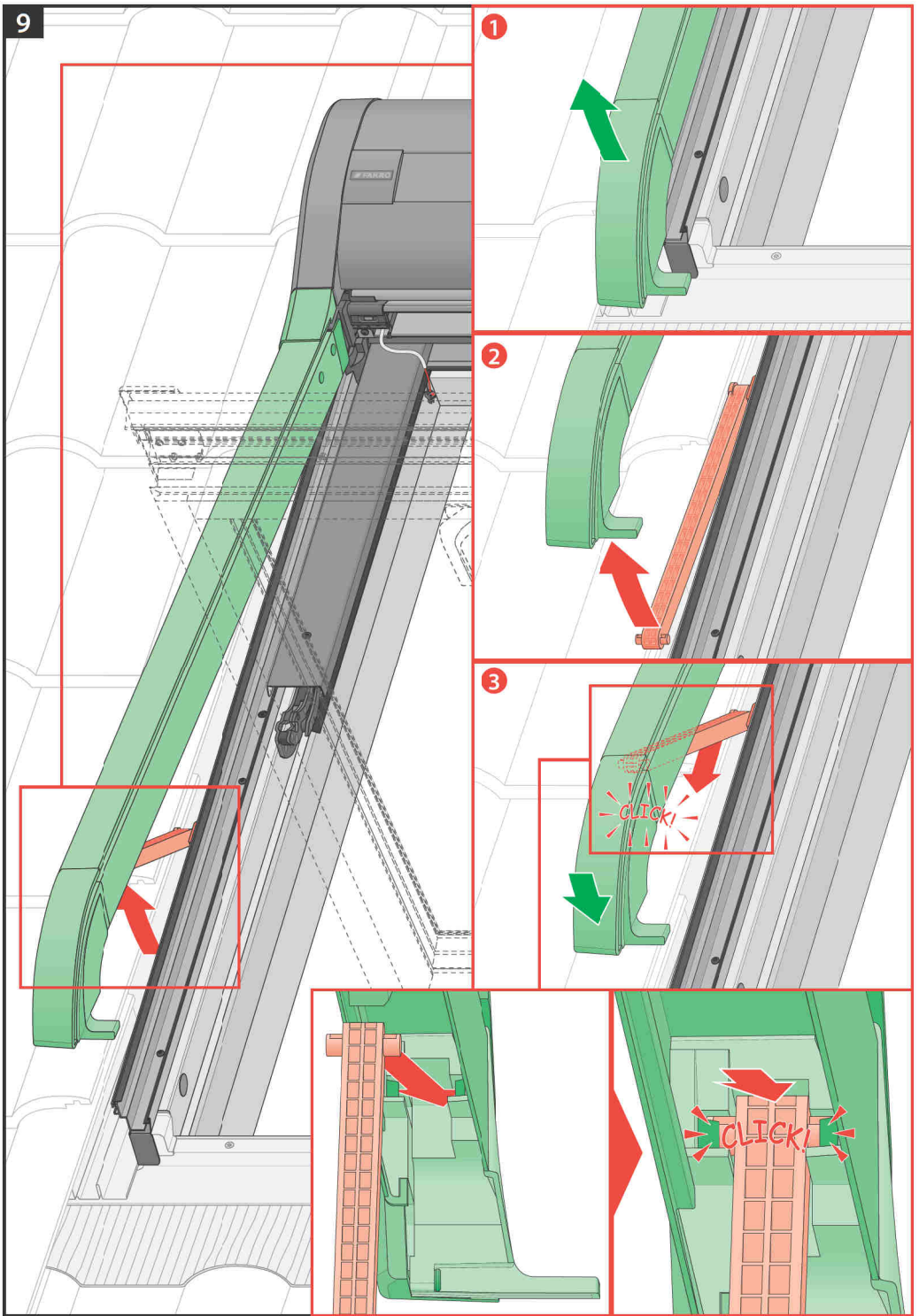

10

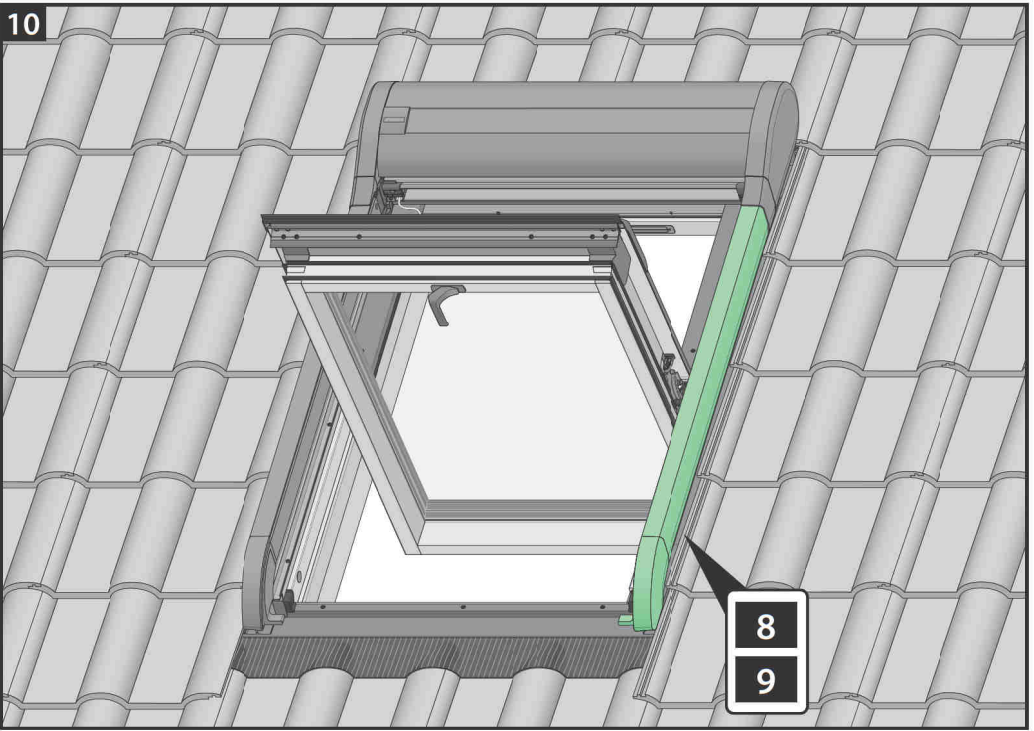

type Z-Wave

11

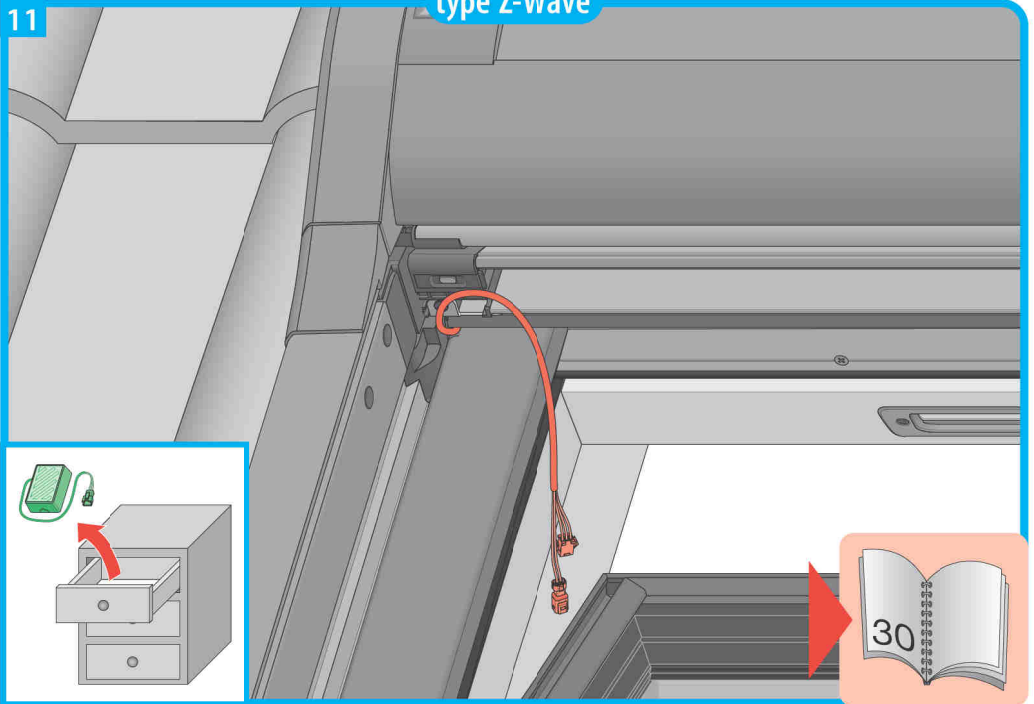

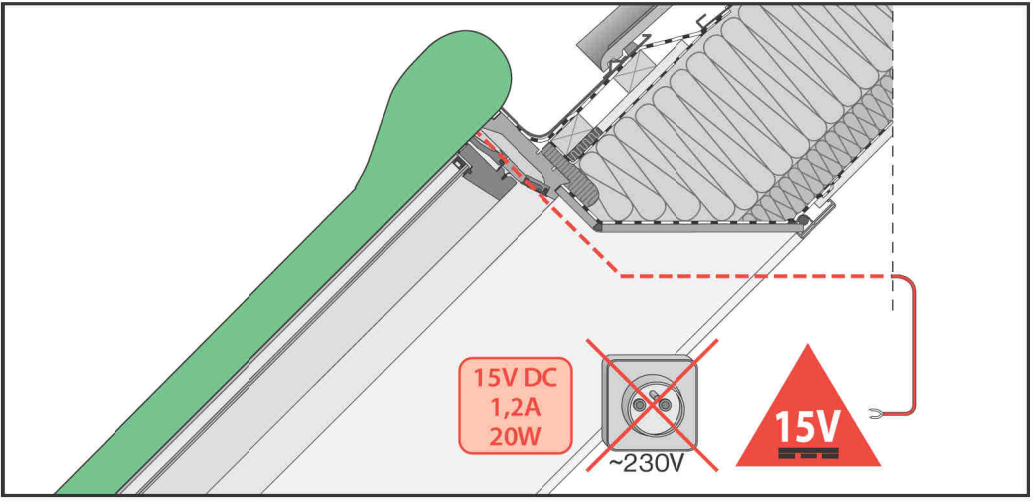
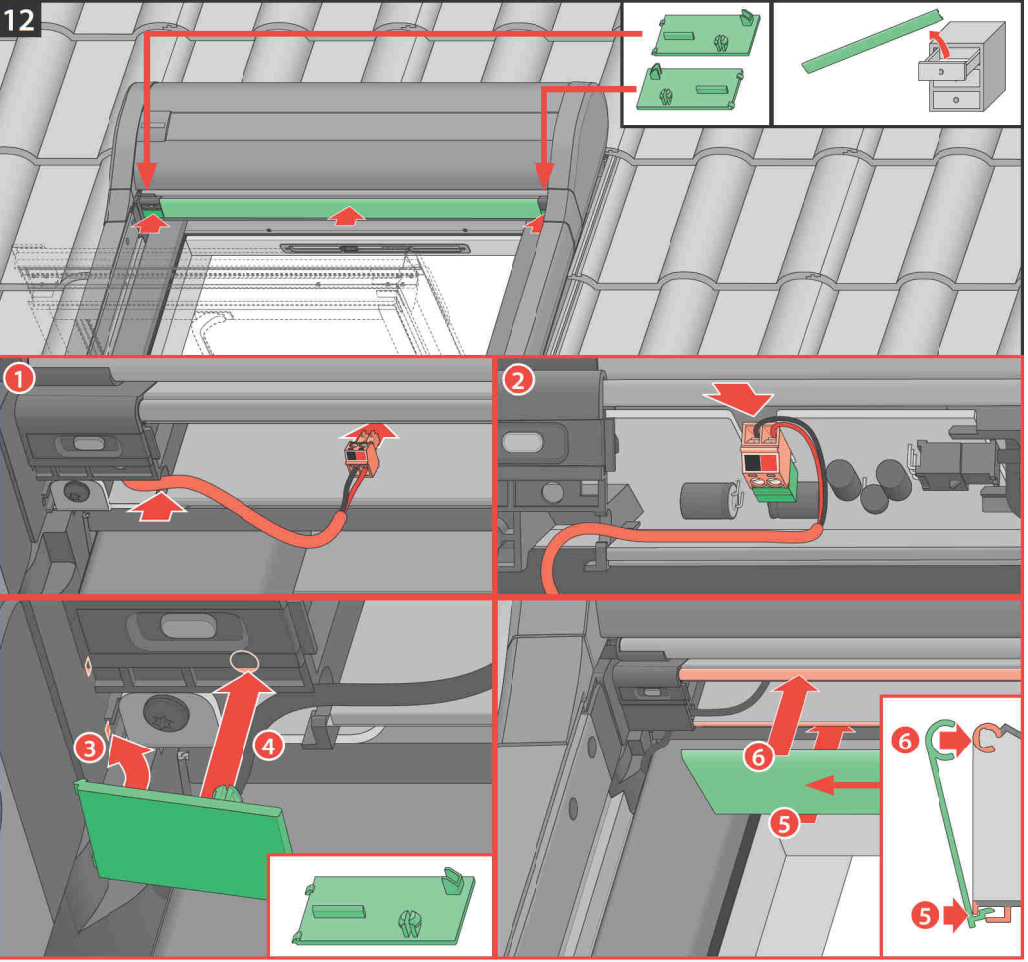

13a

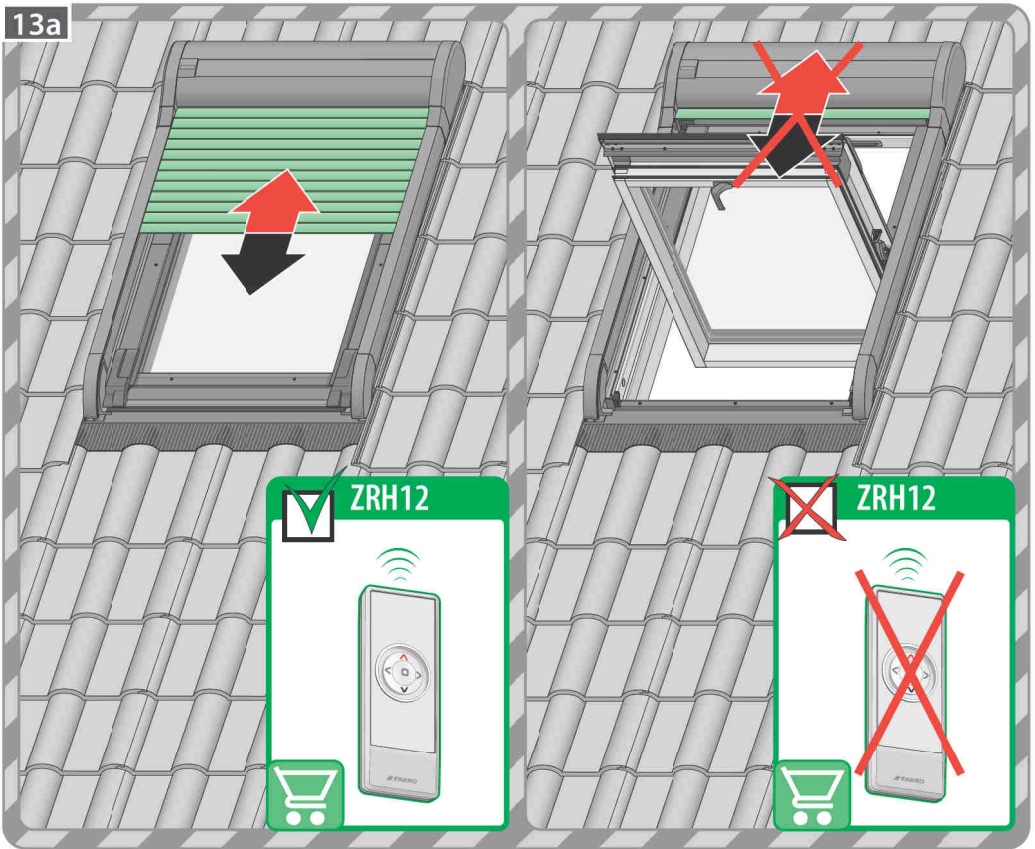

13b

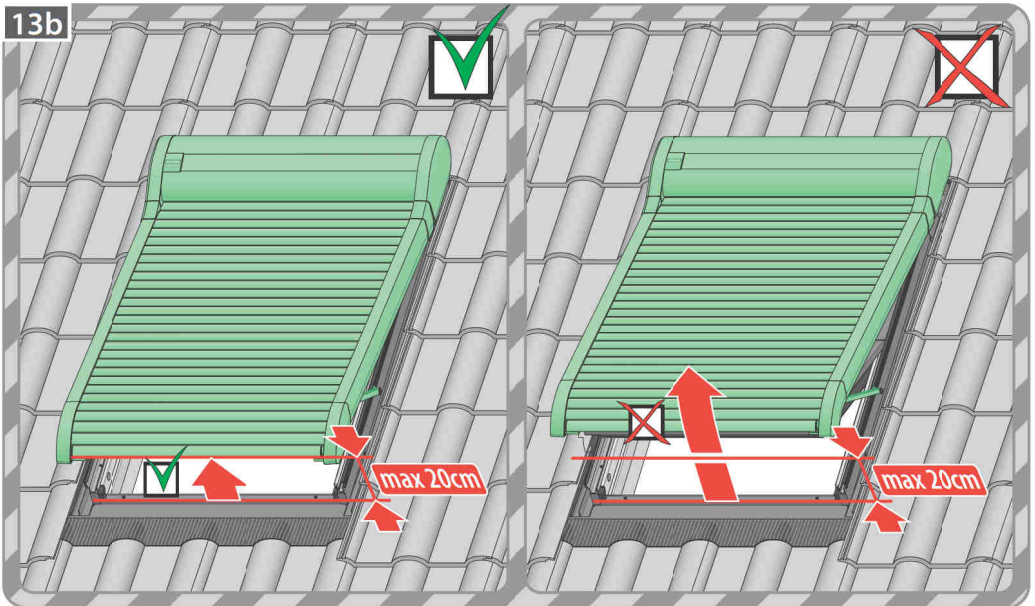

14

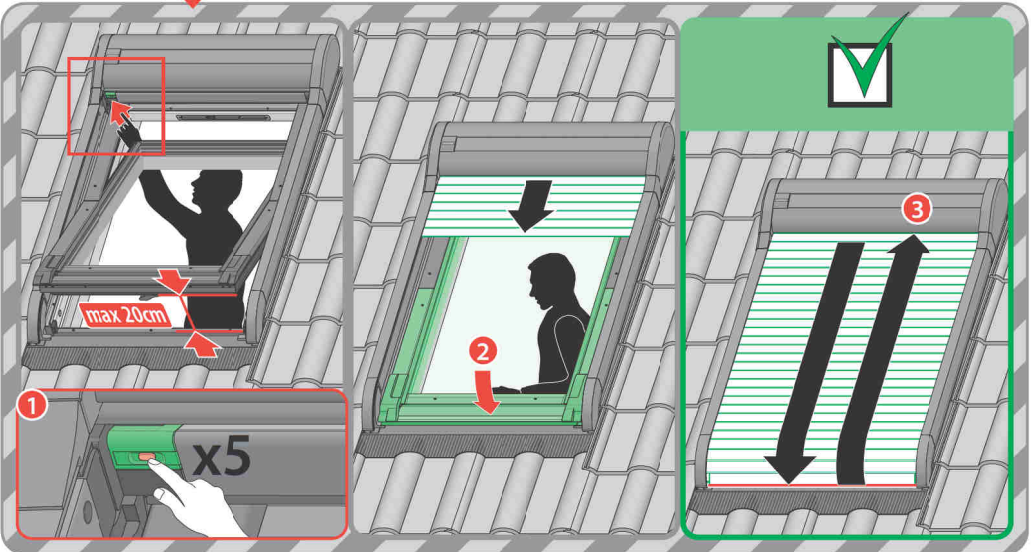
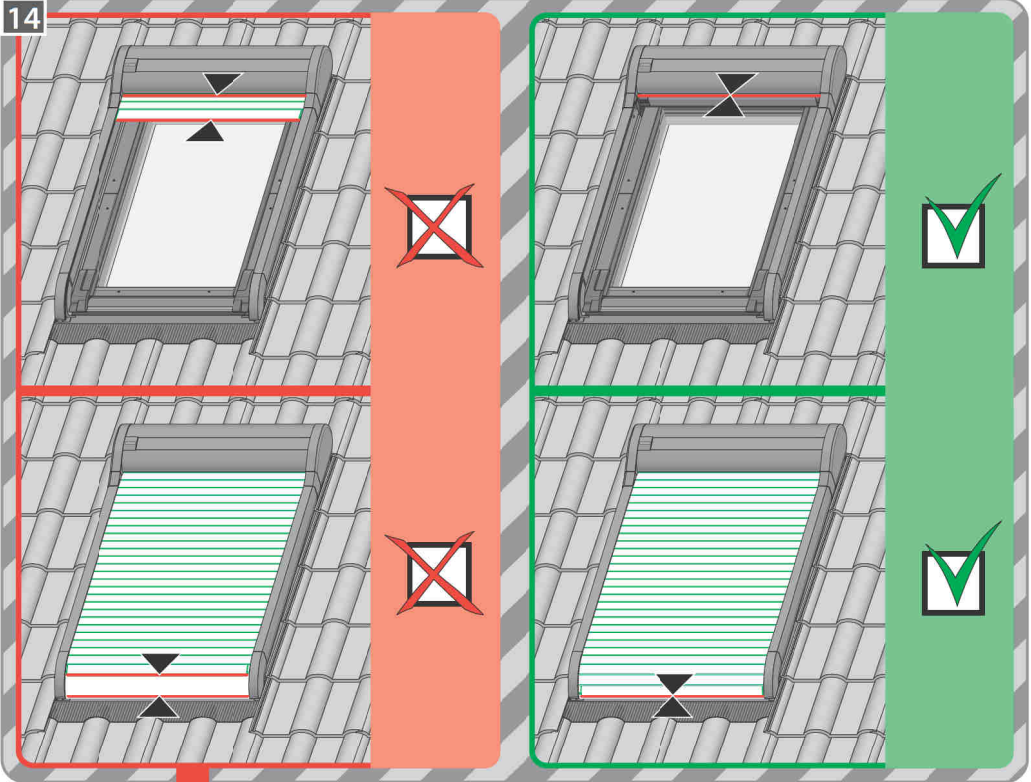

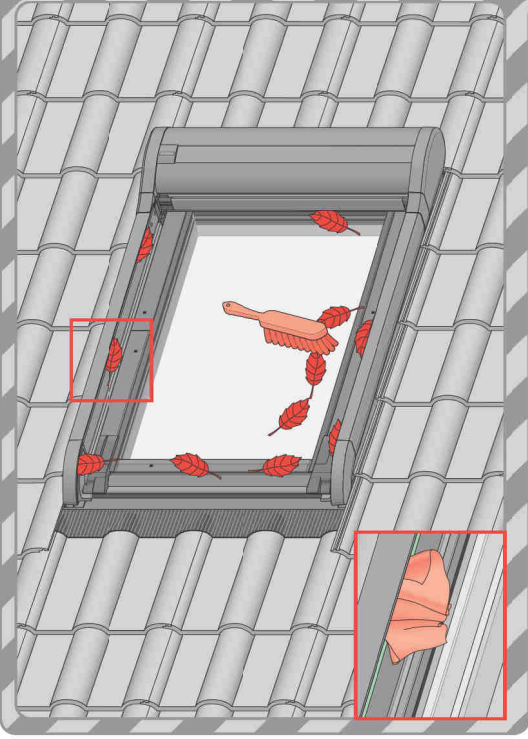
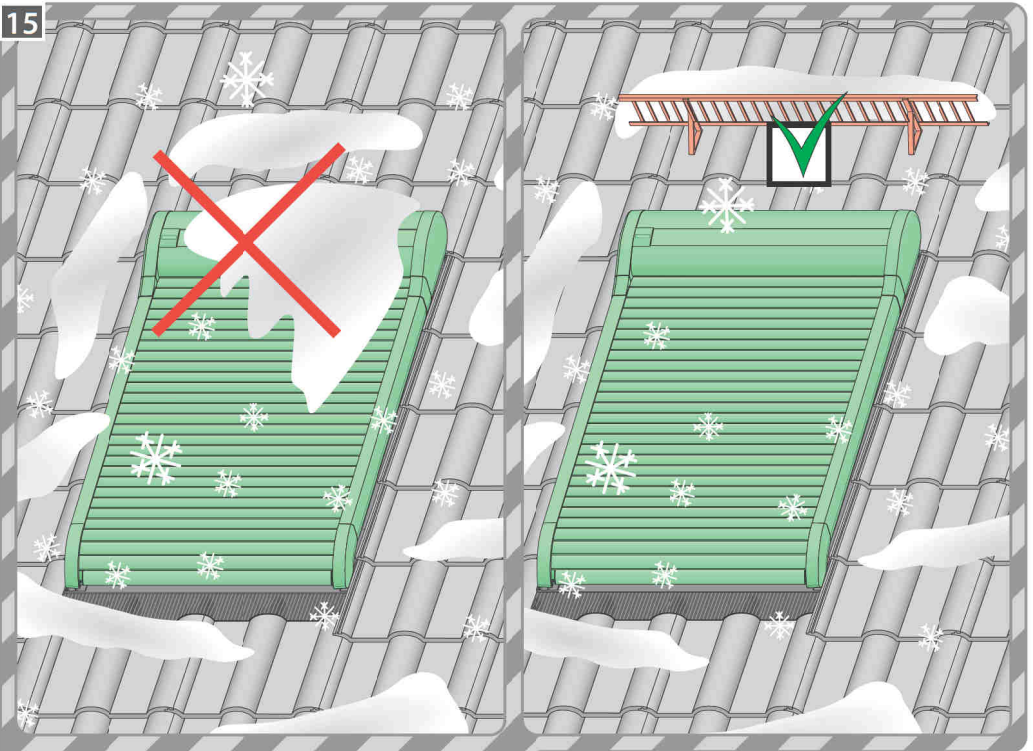

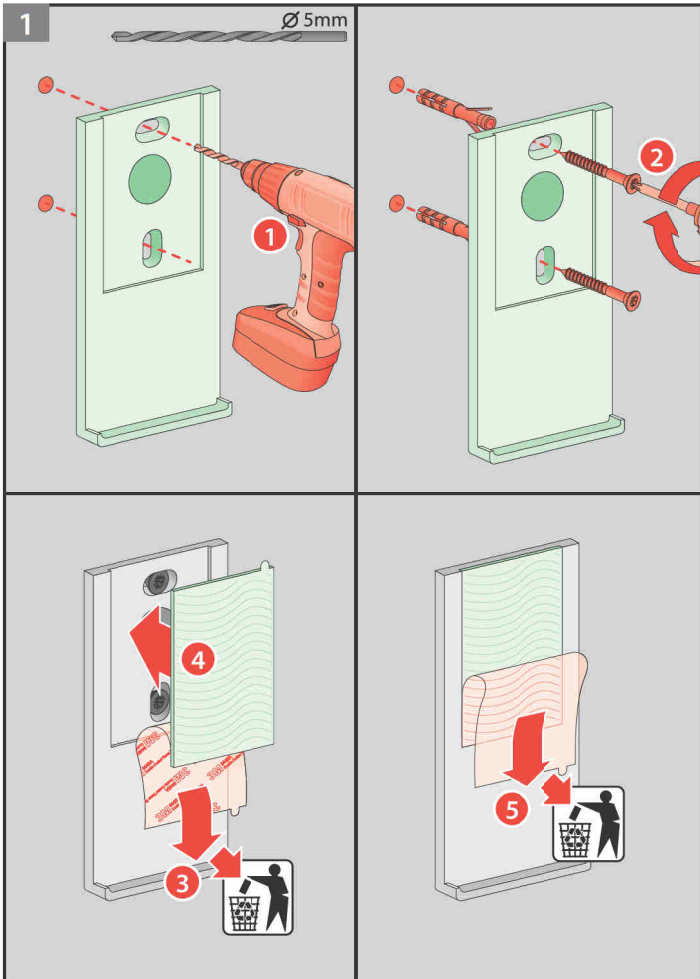

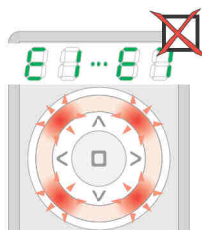
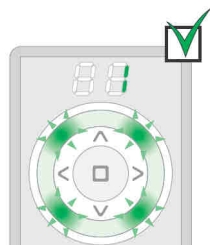
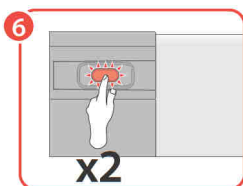
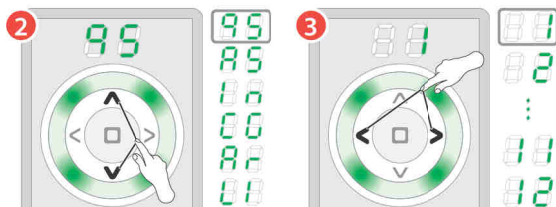
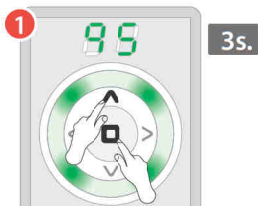
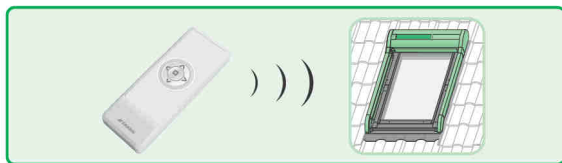

4a

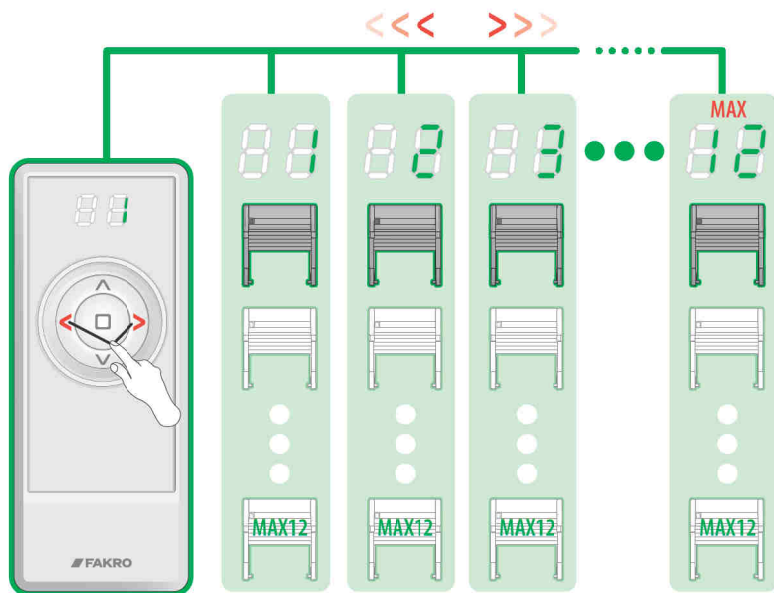

4b

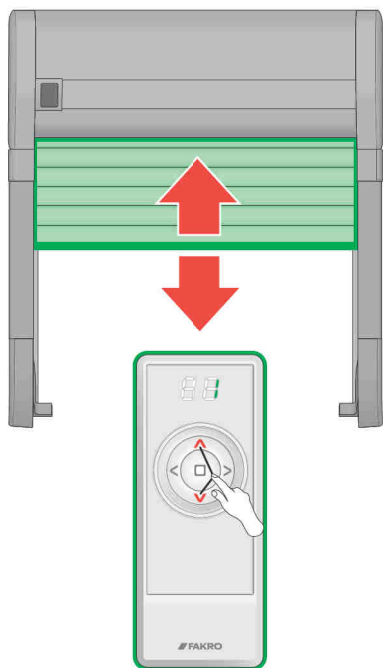

4c

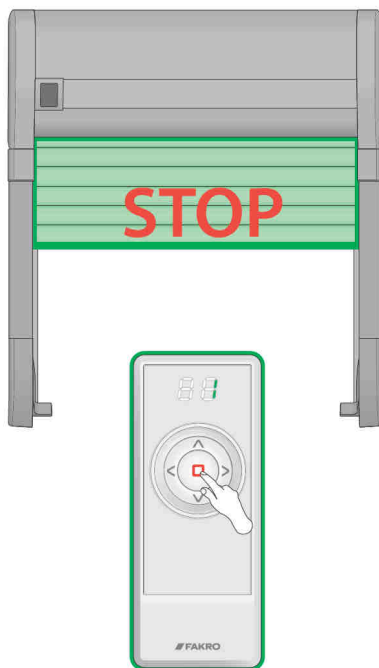

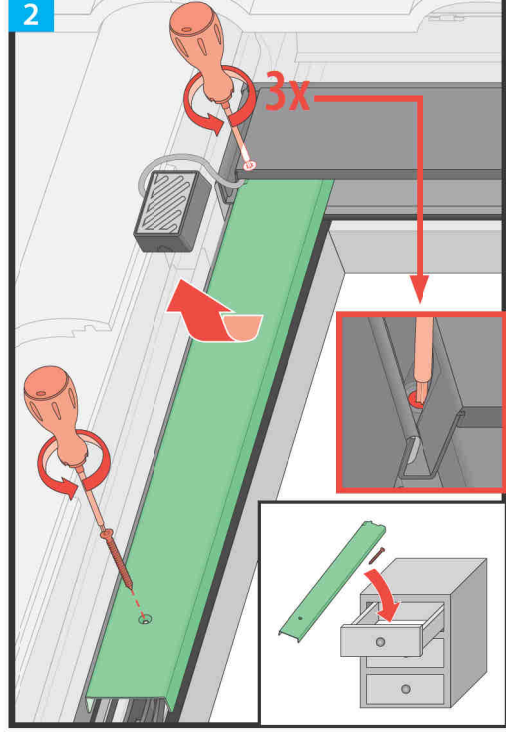
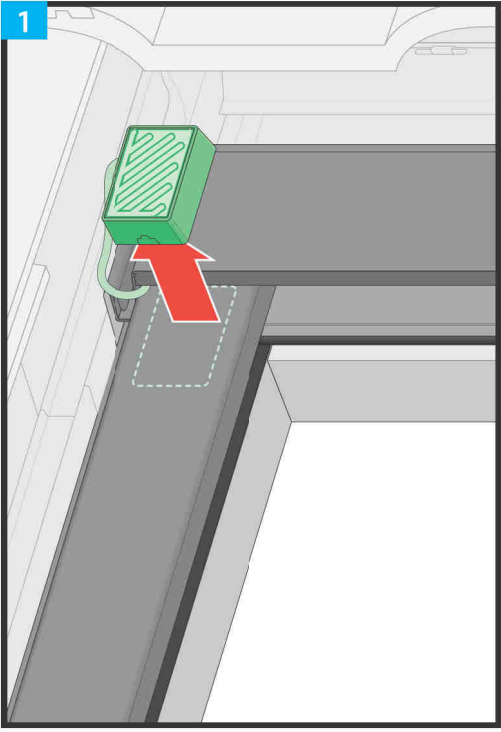
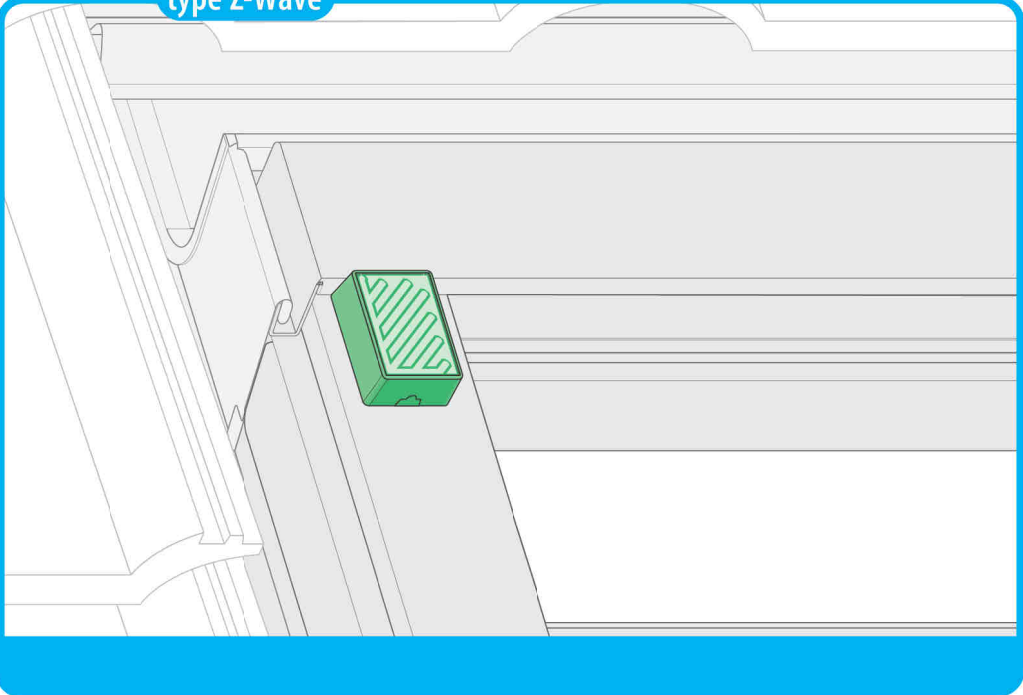

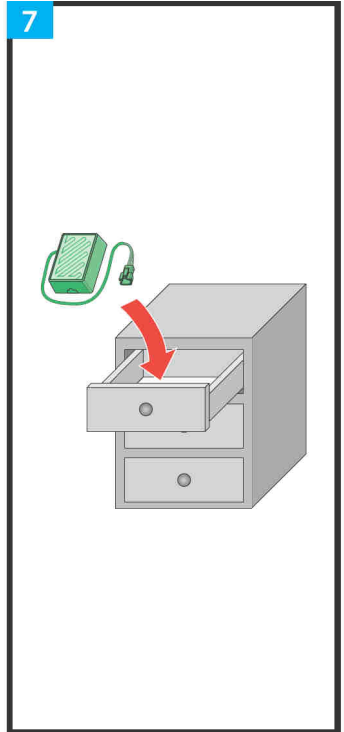
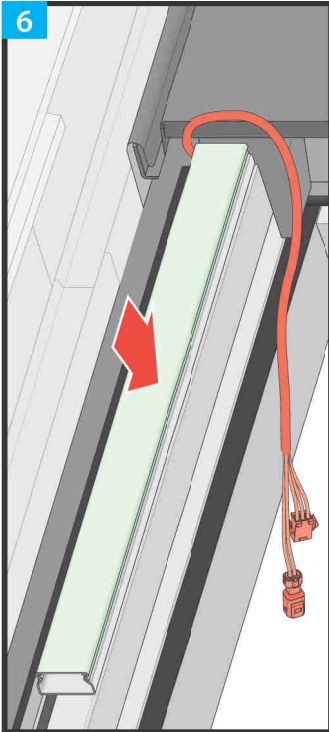
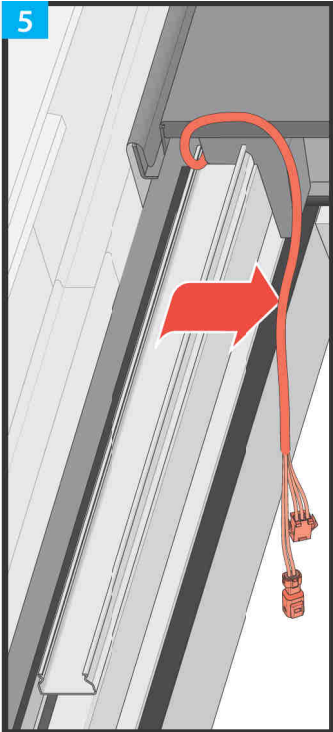
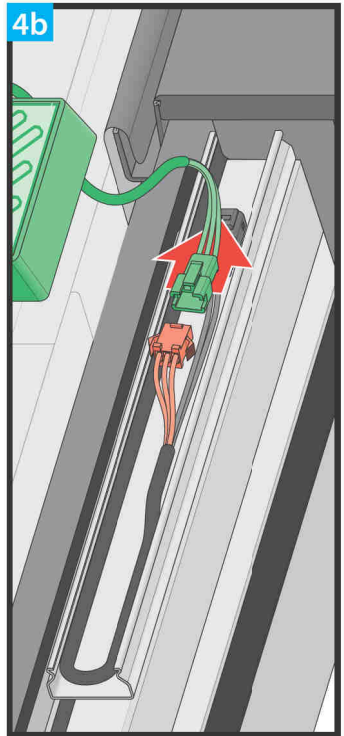
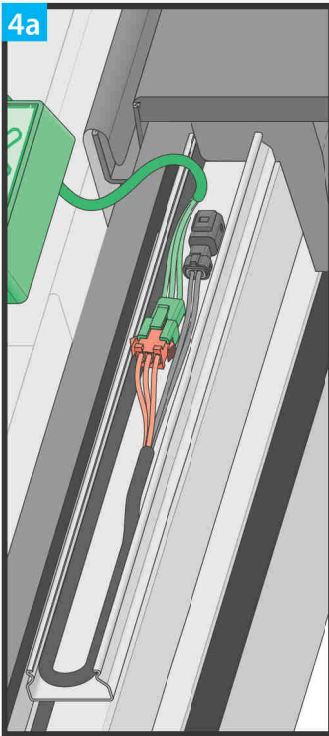
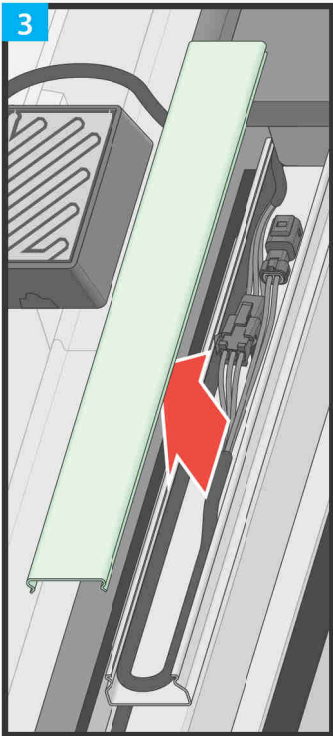

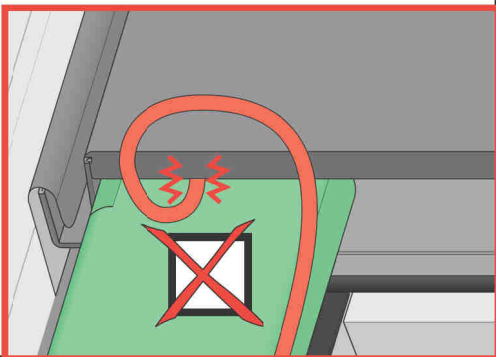
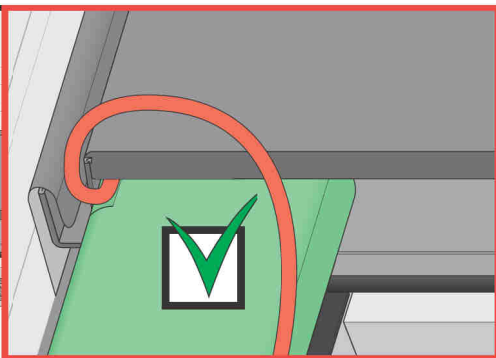
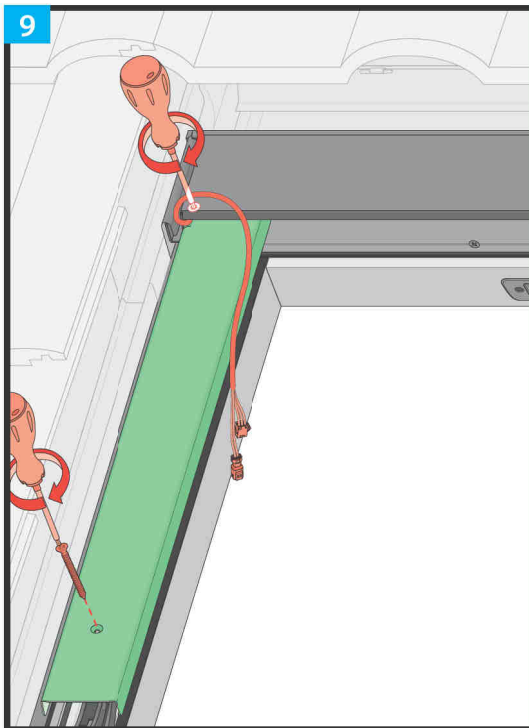
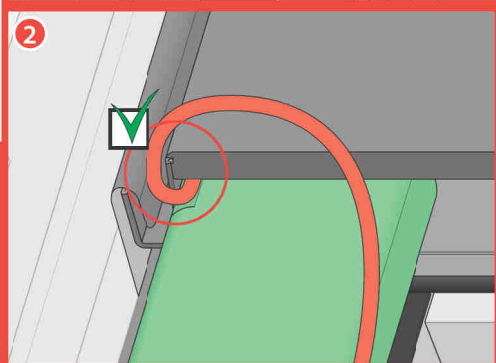
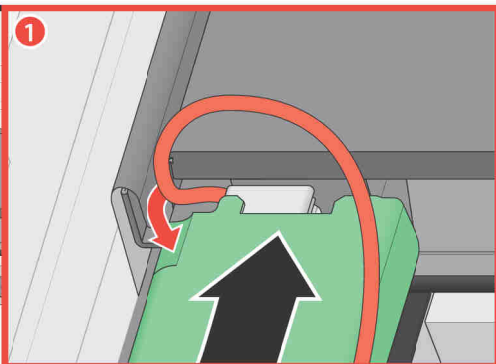
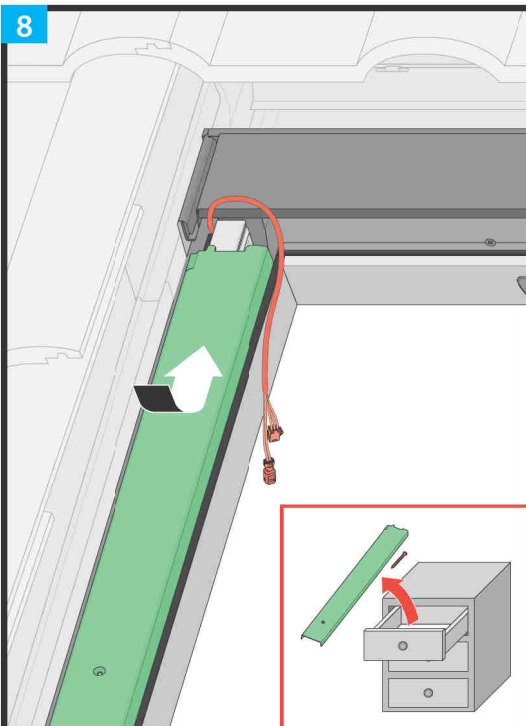

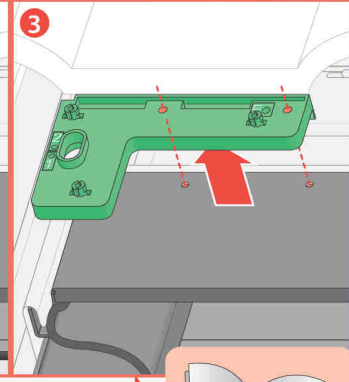
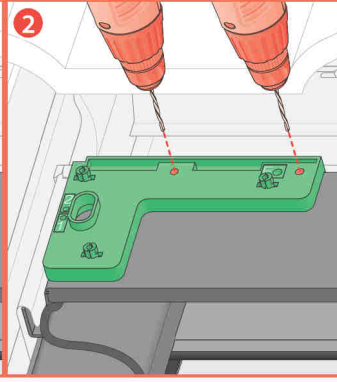
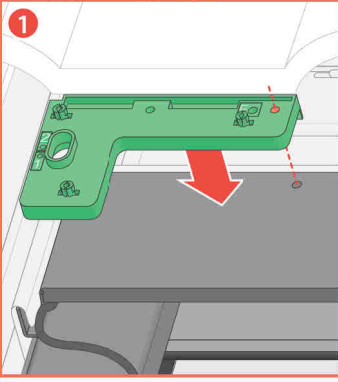
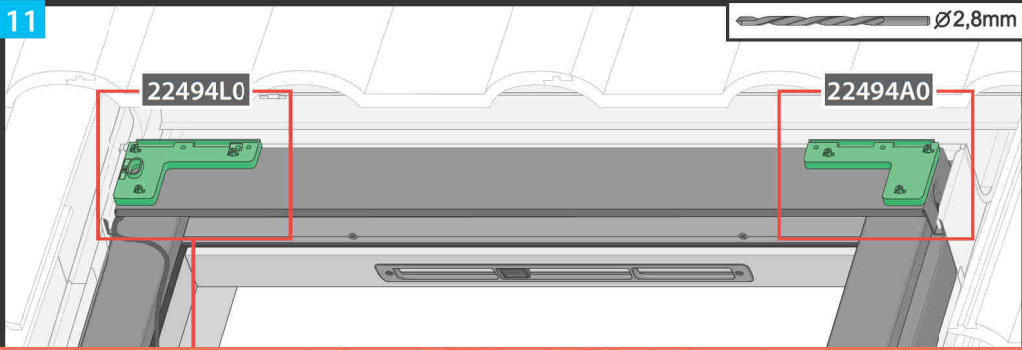
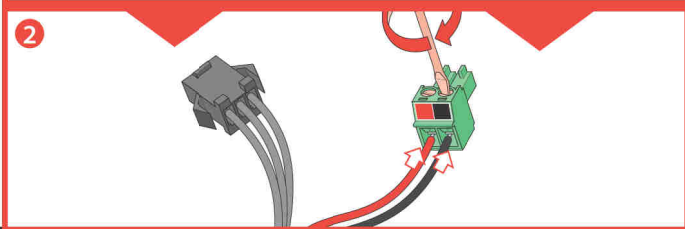
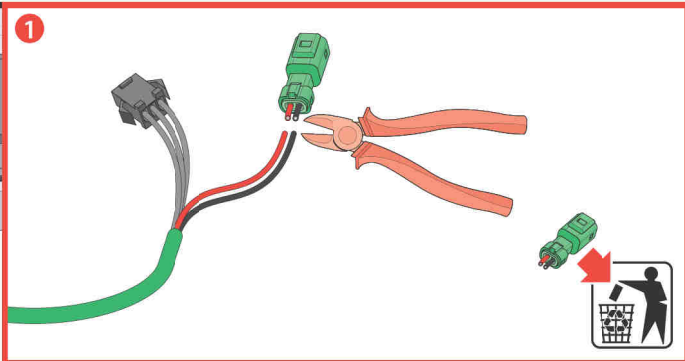
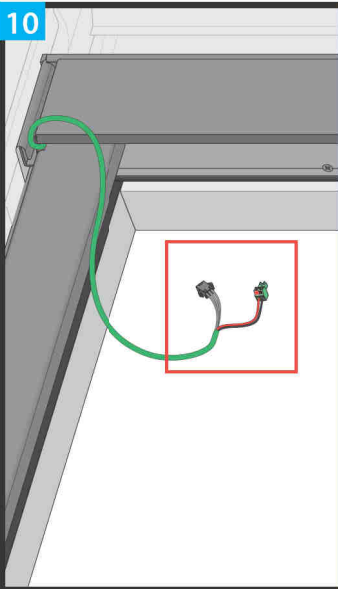

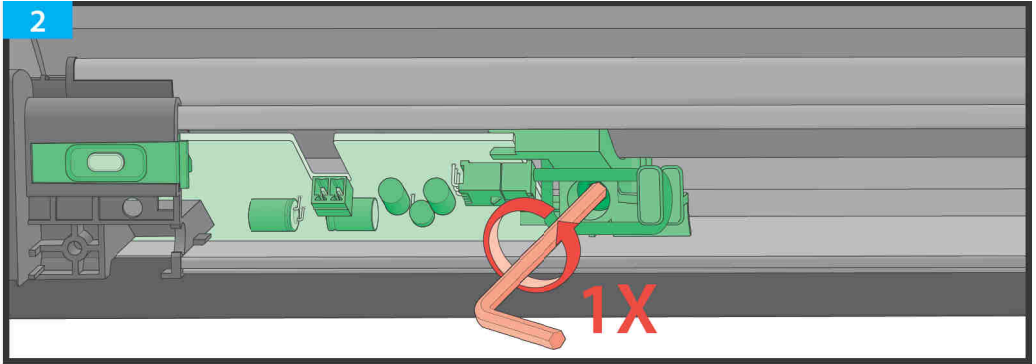
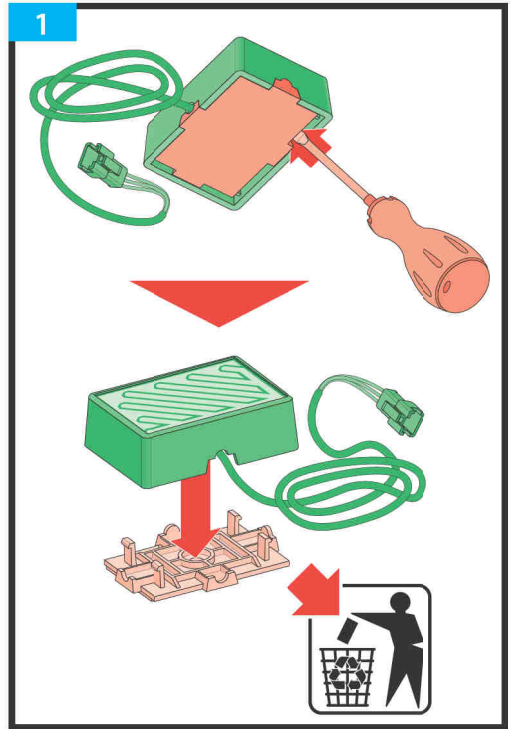
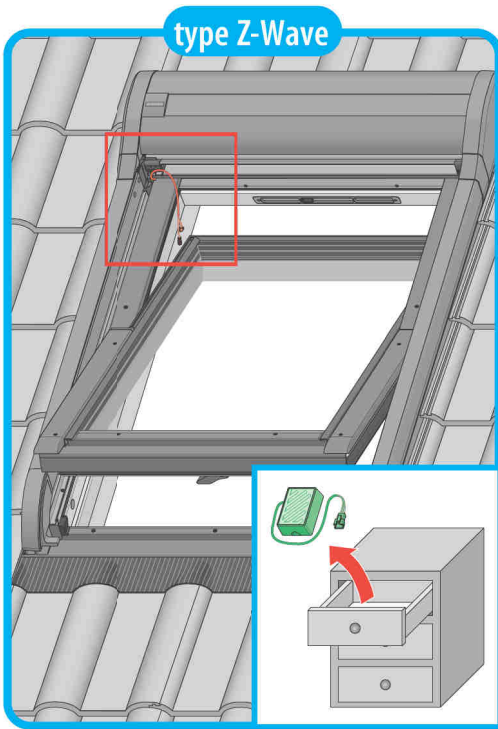

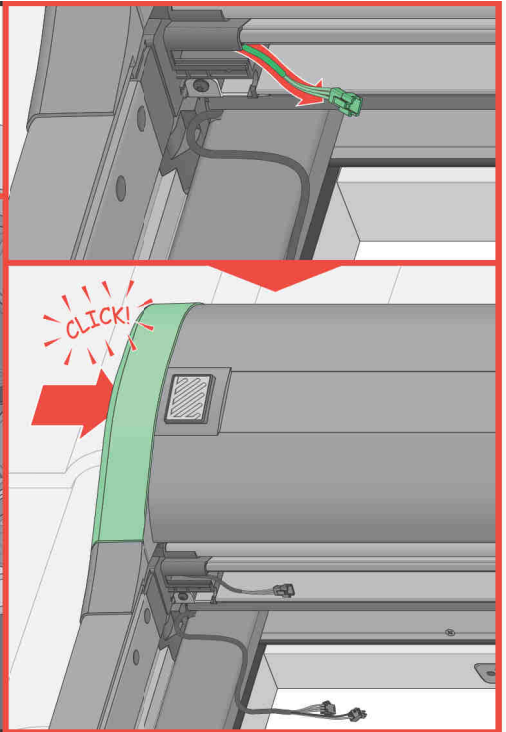
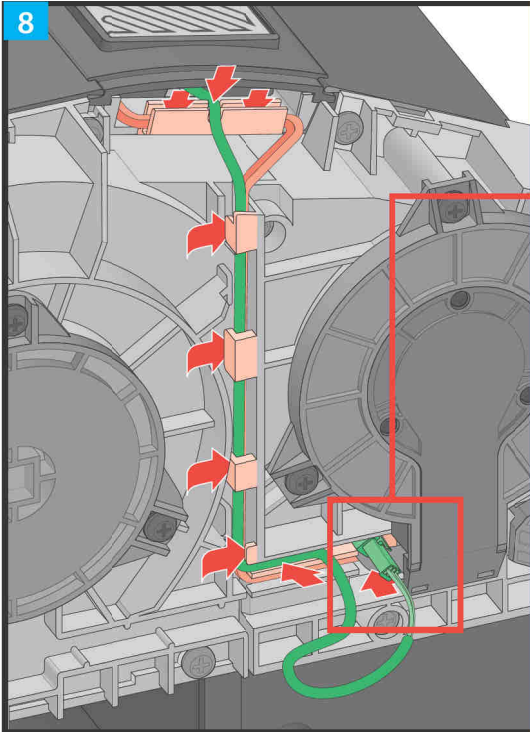
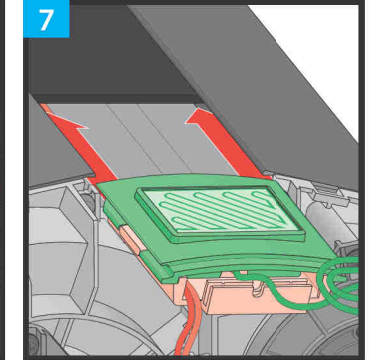
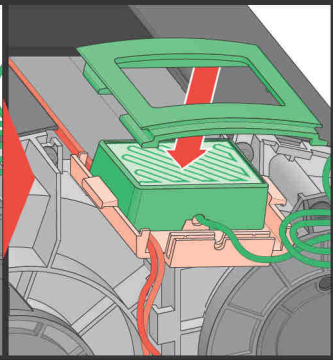
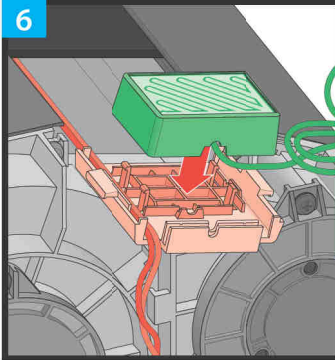
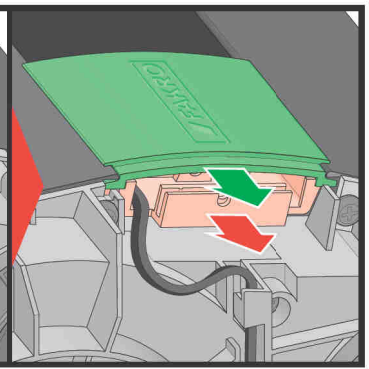
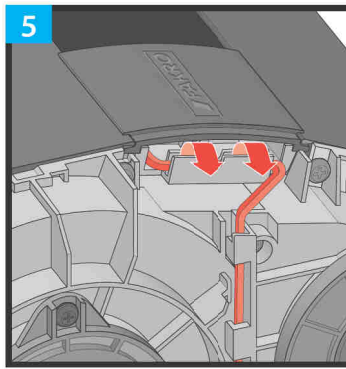
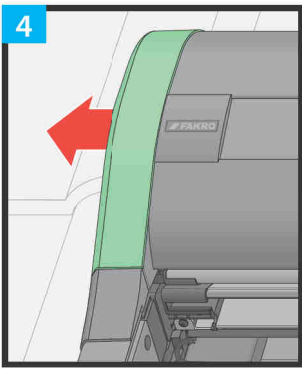

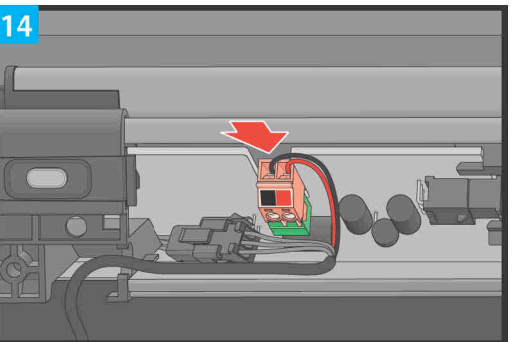
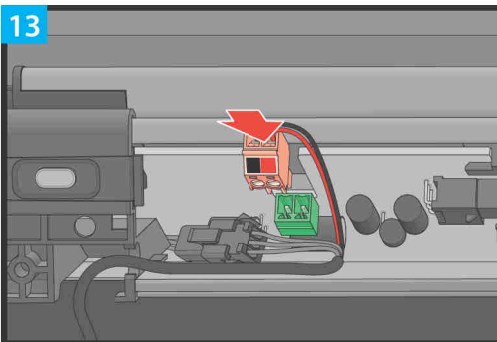
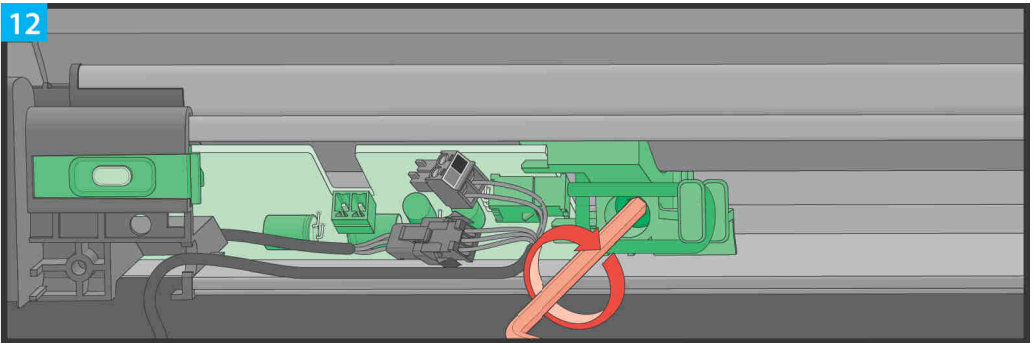
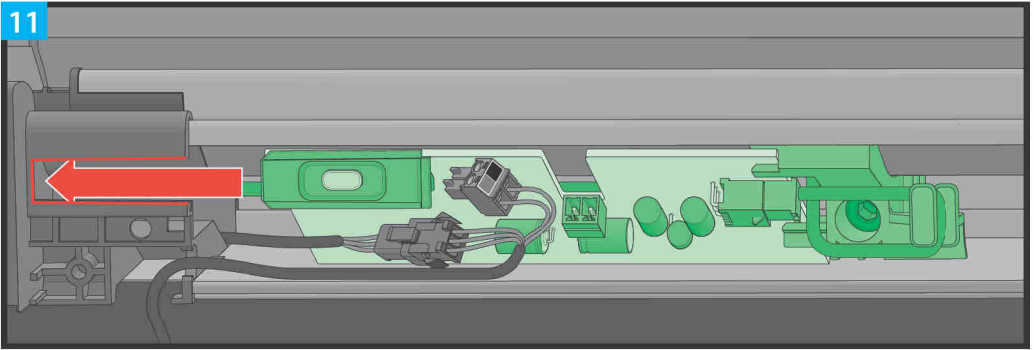
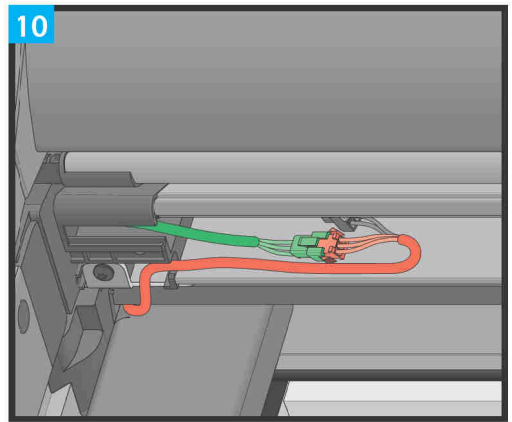
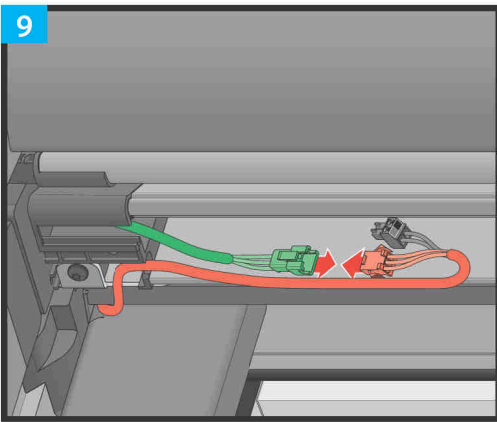

15

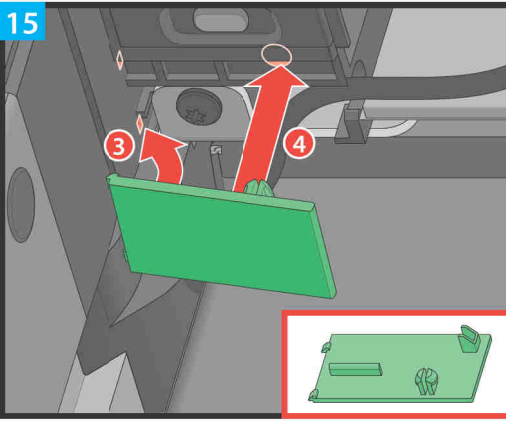

16

