

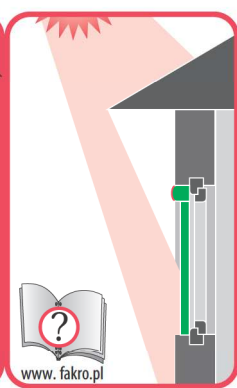

VMB Z-Wave Solar

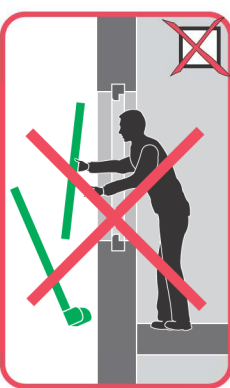

EN	Before installation, it is compulsory to read the NC867 "ORIGINAL INSTRUCTIONS 2/3 Installation and user manual".
1	Remove the side guide rails.
1a, 1b	Remove the cover strip from the battery compartment.
1c, 1d	Install the battery and install the cover strip.
1e	Connect the side guide rails with the awning cassette.
2a	Place the roll-up awning in the window opening.
2b	Check the roll-up awning for correct installation.
3	Screw the roll-up awning to the window or to the lining.

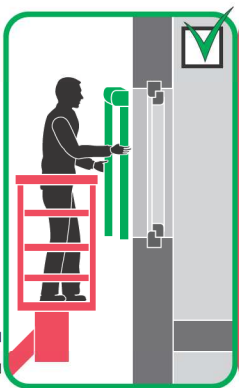
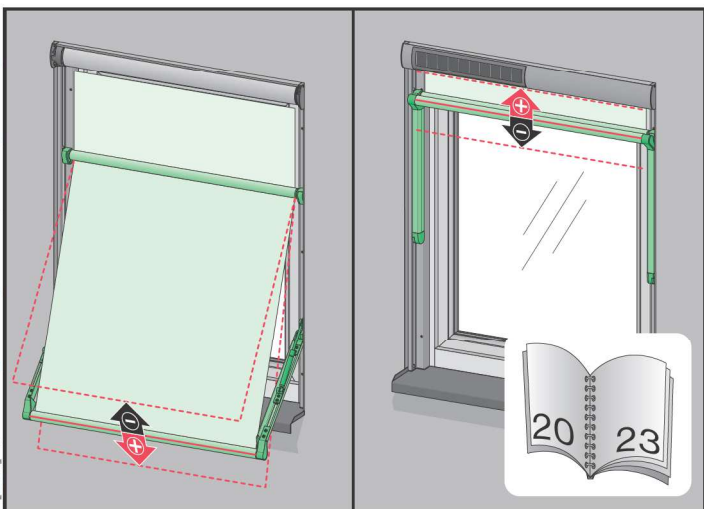
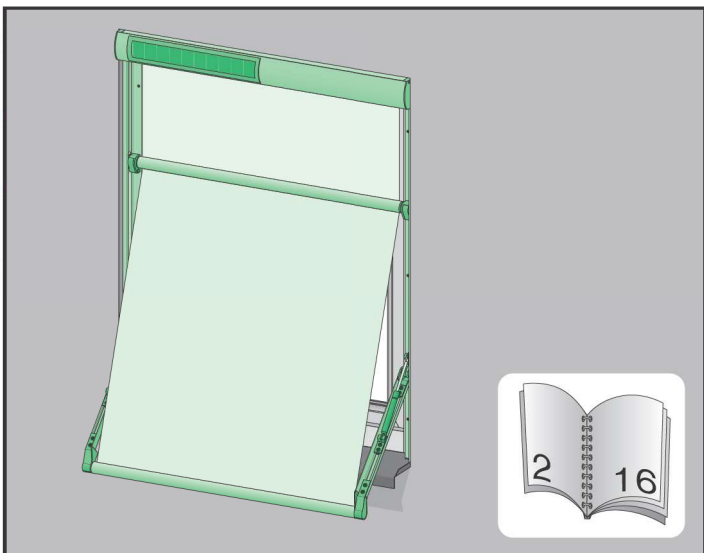

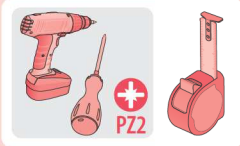

VMB Z-Wave Solar

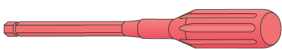
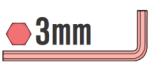
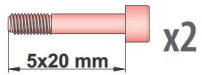
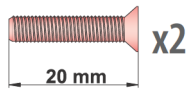
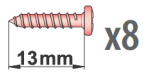
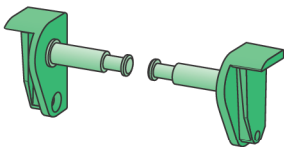
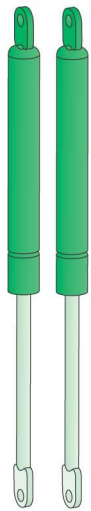
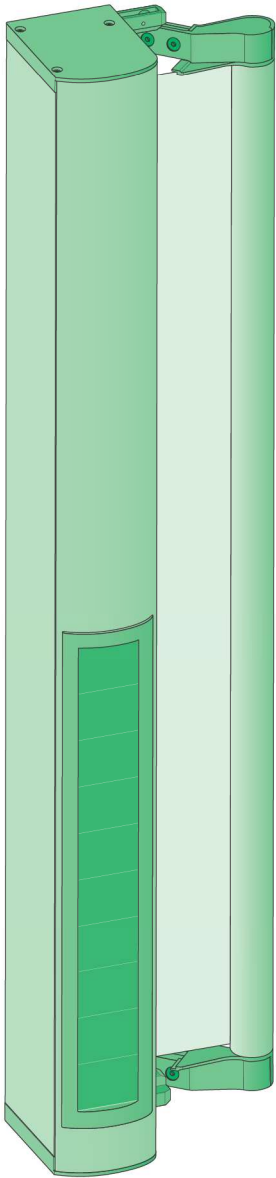

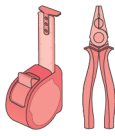

VMB Z-Wave Solar type C

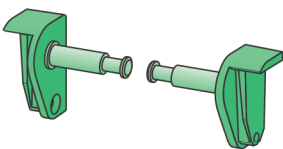
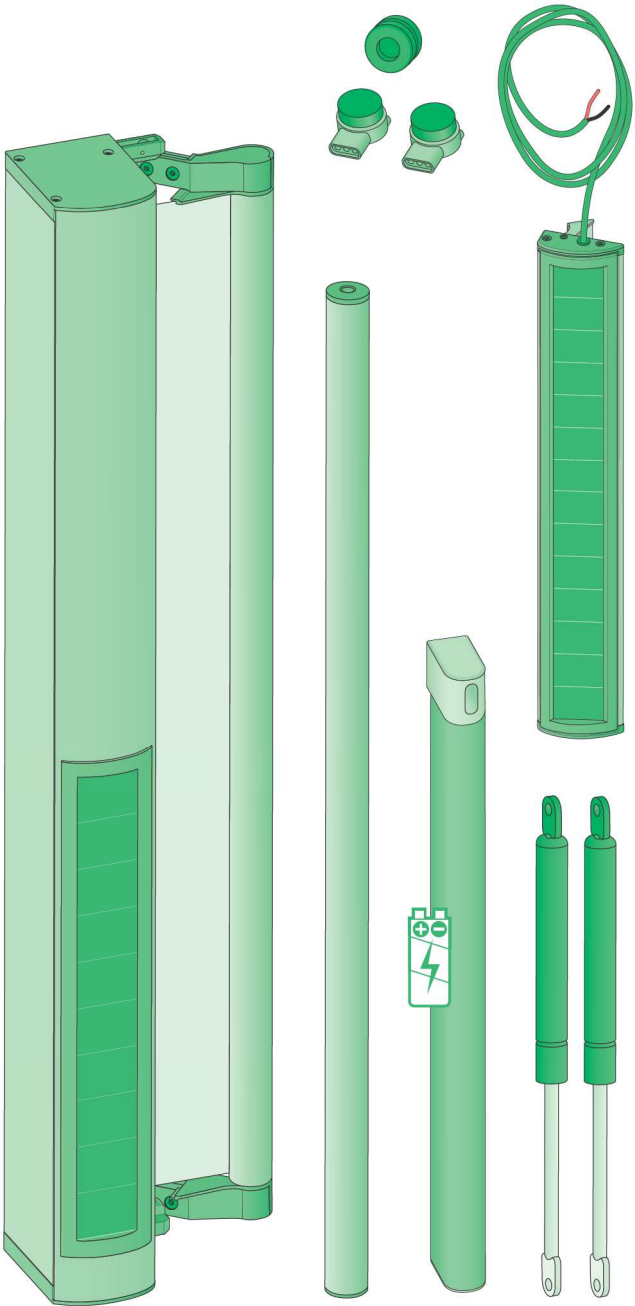

13mm x8

20 mm x2

5x20 mm x2

x4

3mm

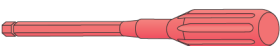

Ø2mm

1

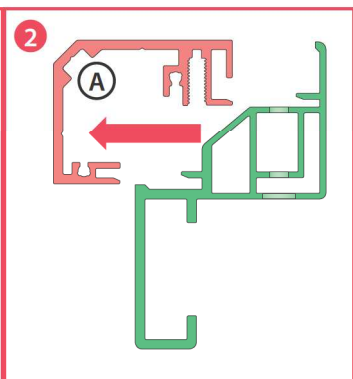
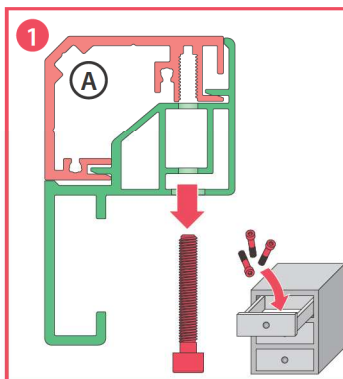
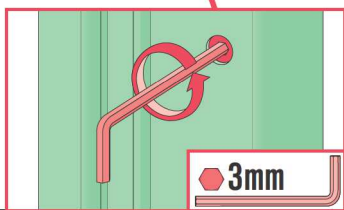
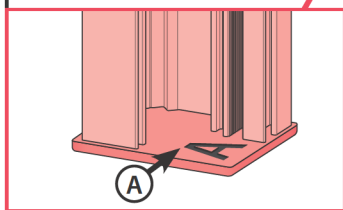
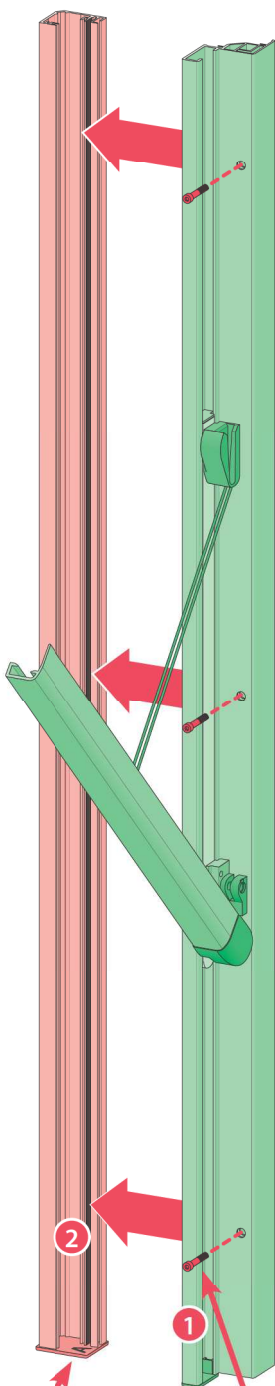
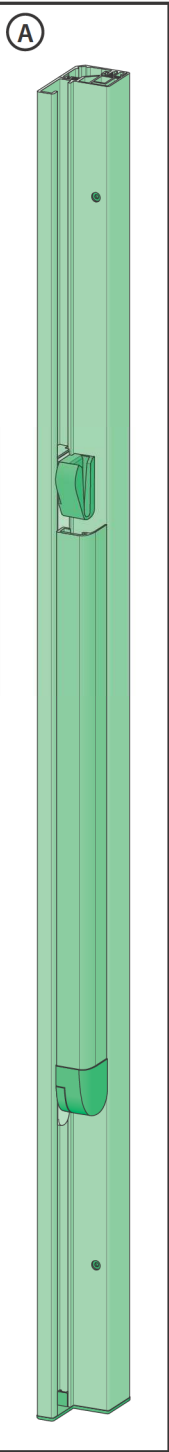

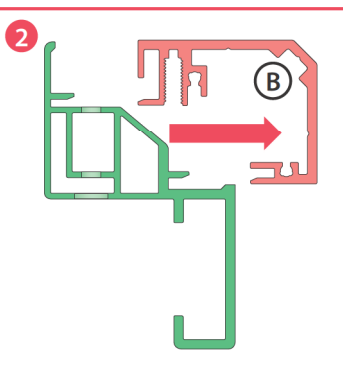
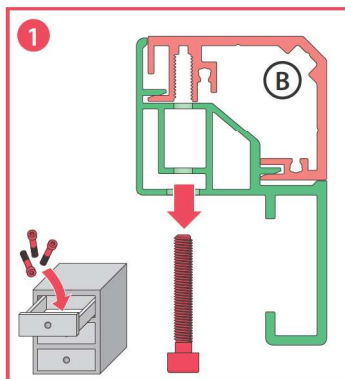
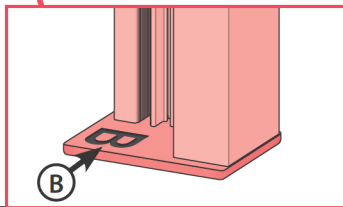
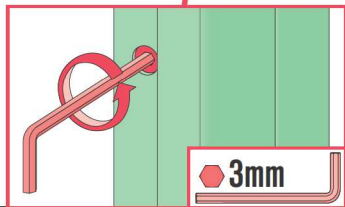
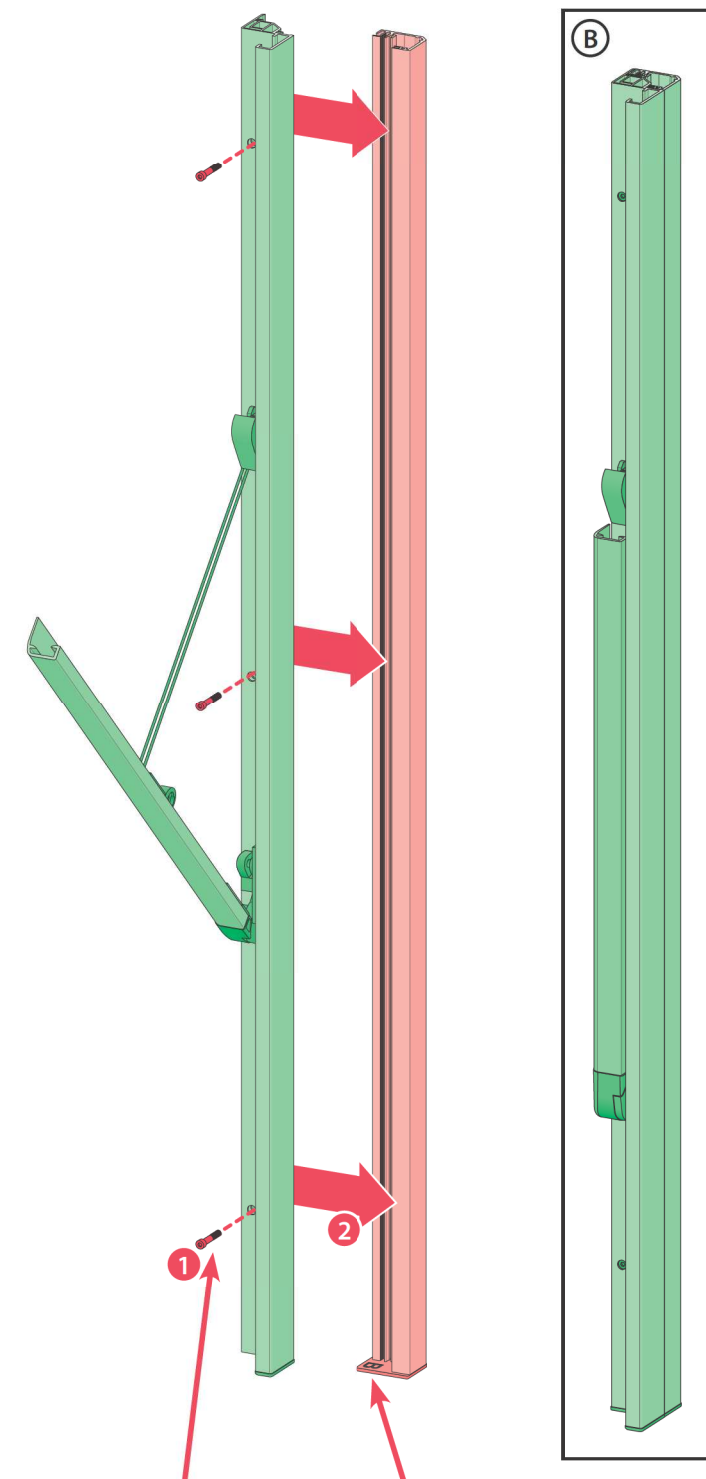

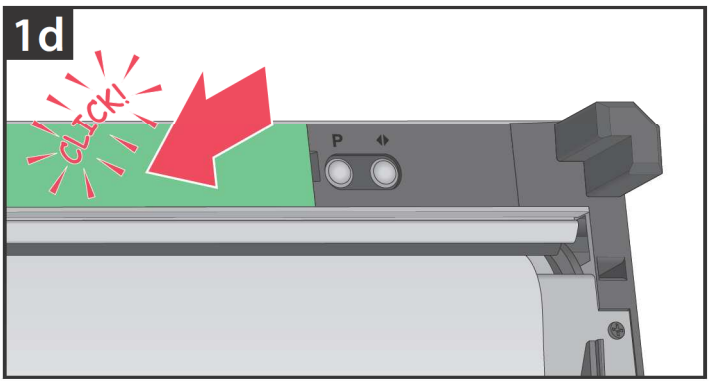
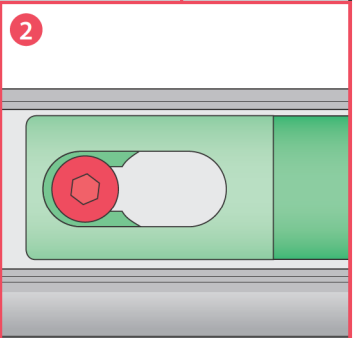
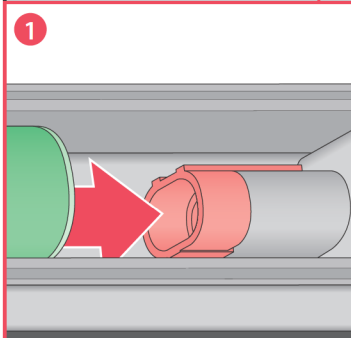
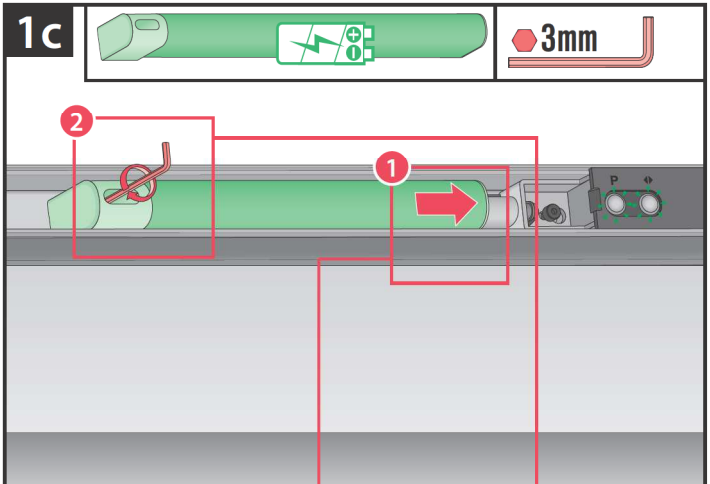
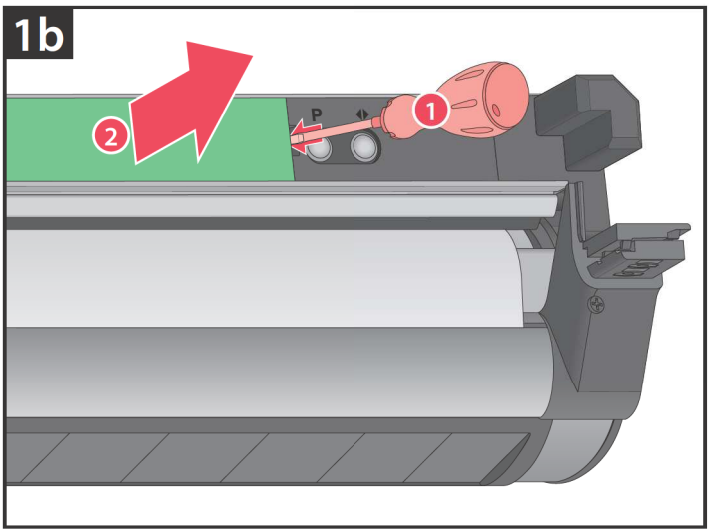
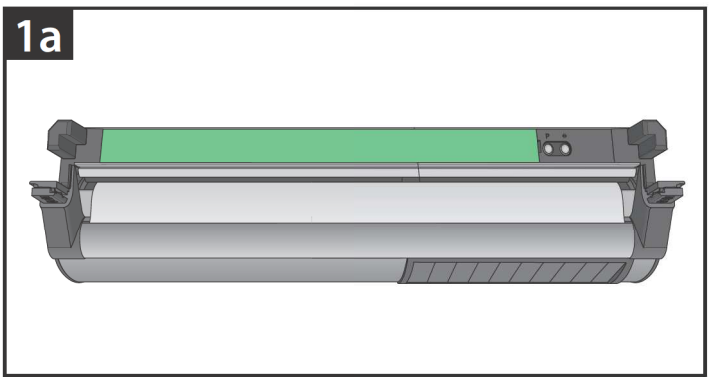

1e

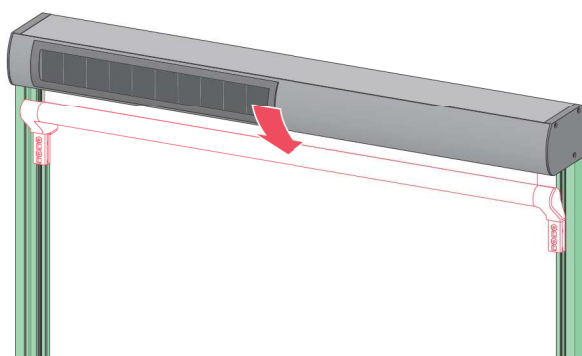
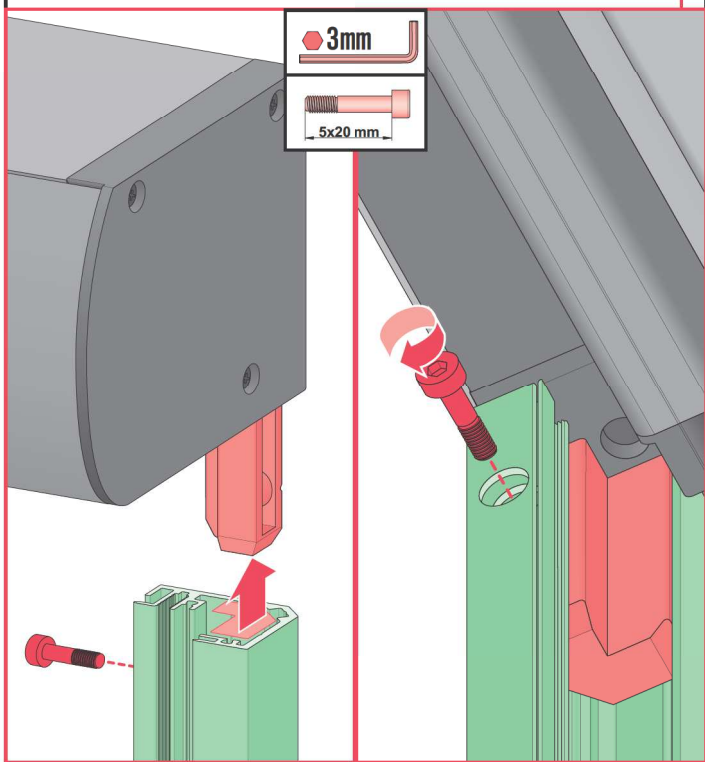
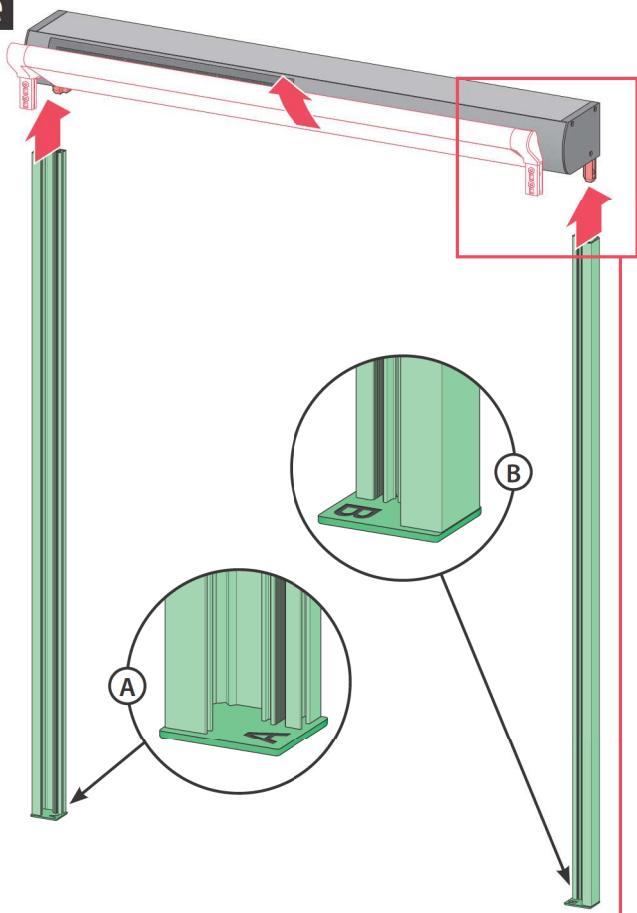

2a

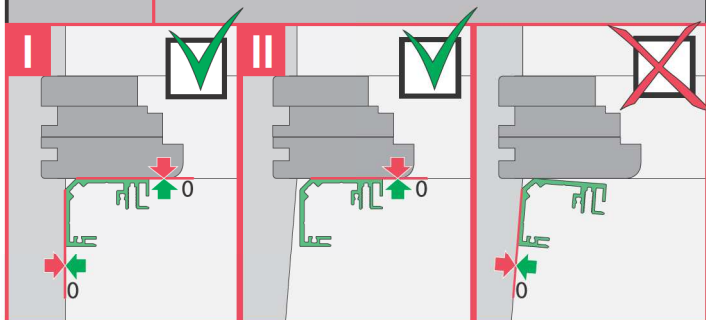
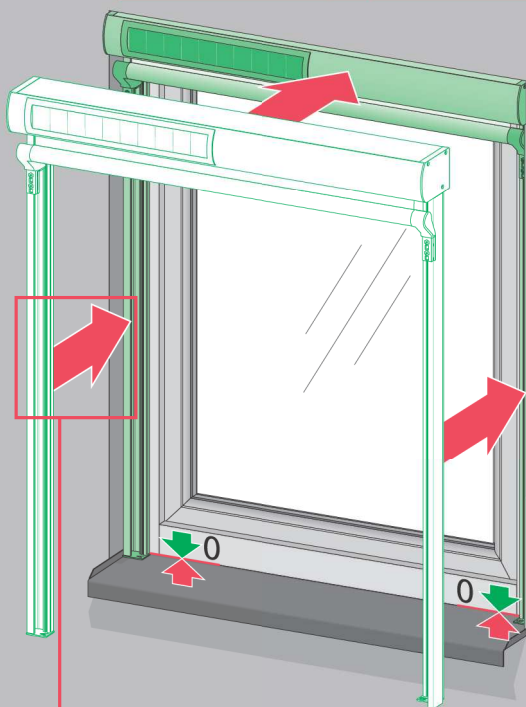
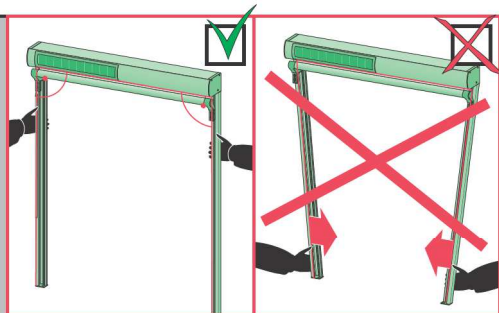

2b

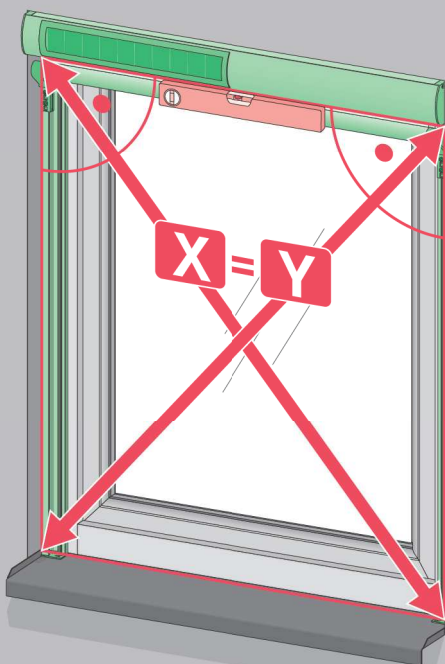

3

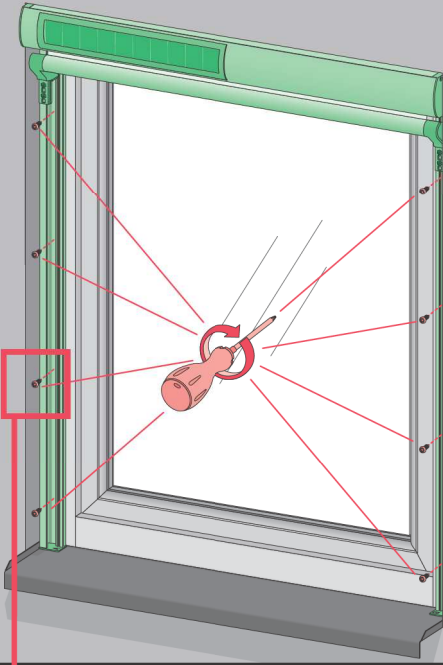

I

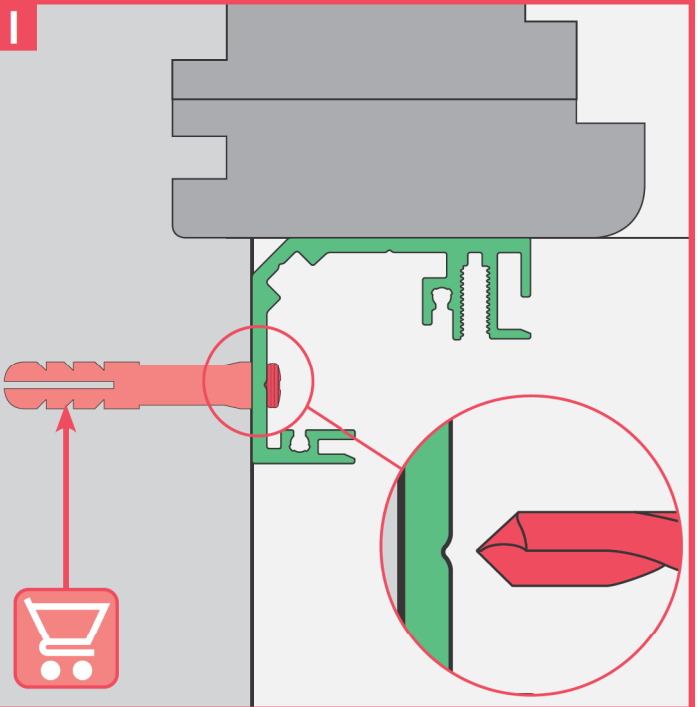

II

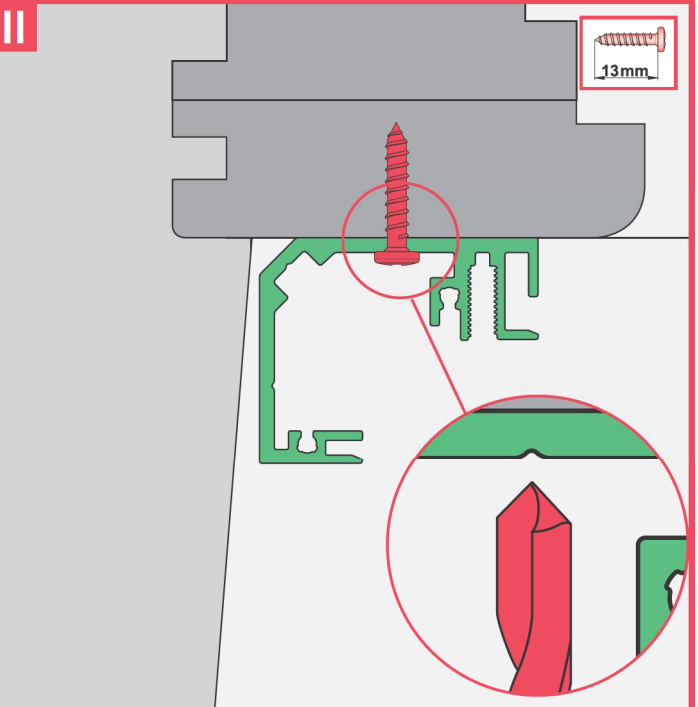

4a

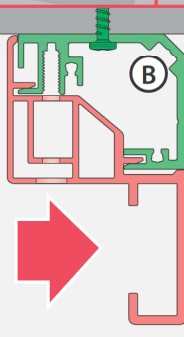
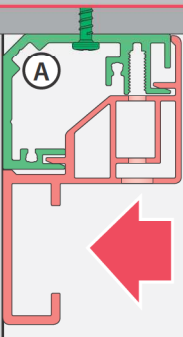
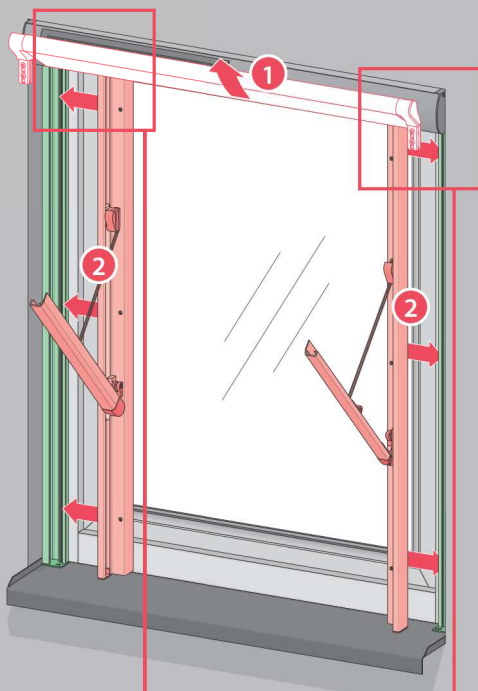

4b

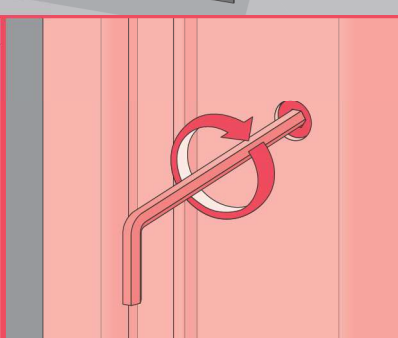
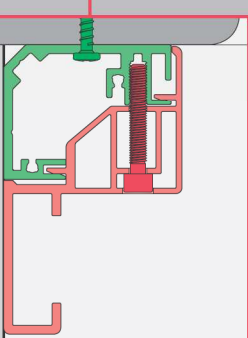
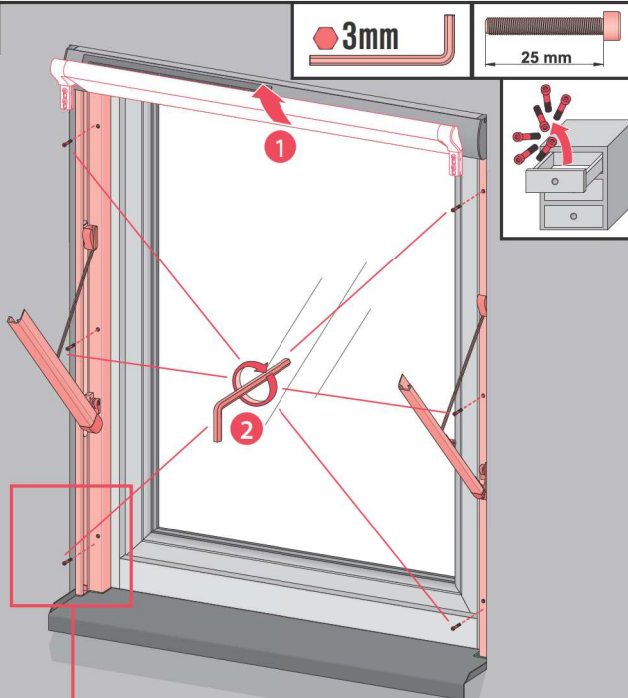

5

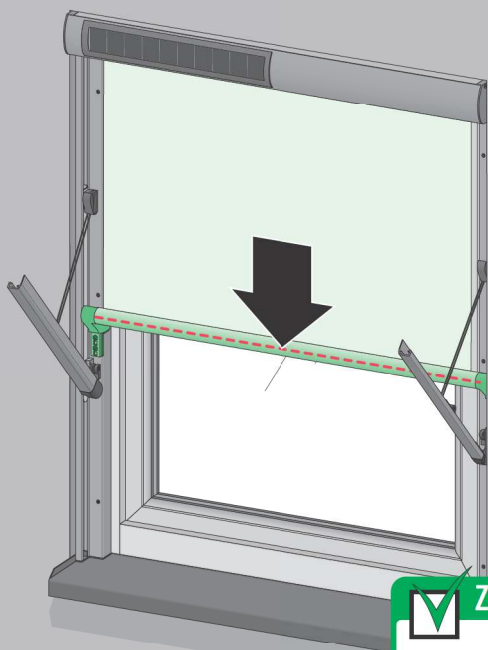

6

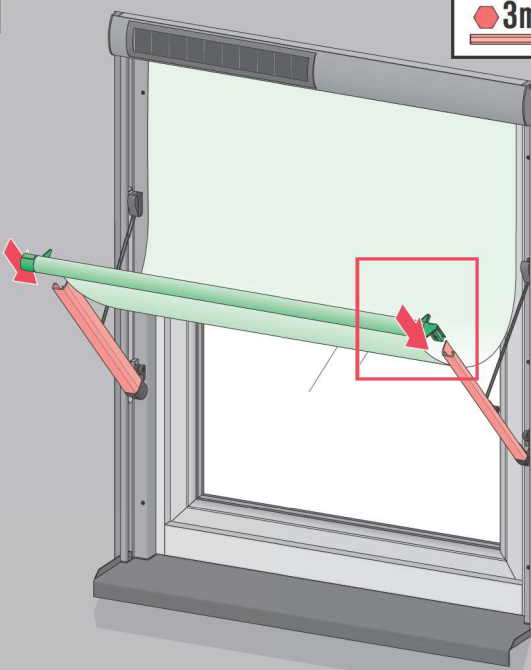

1

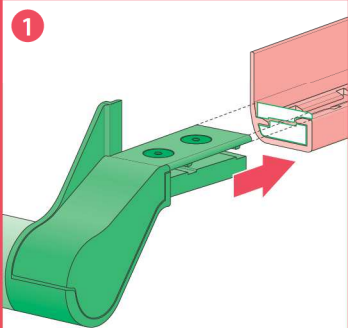

2

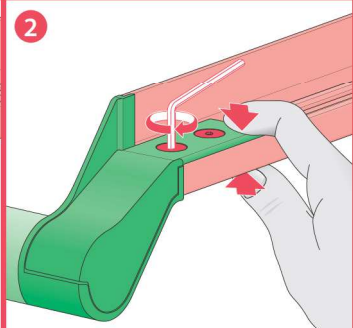

7a

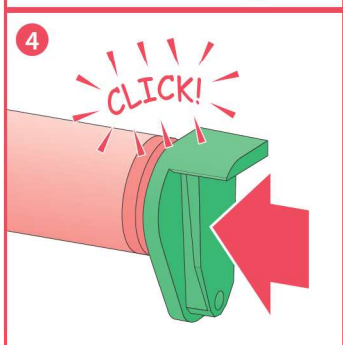
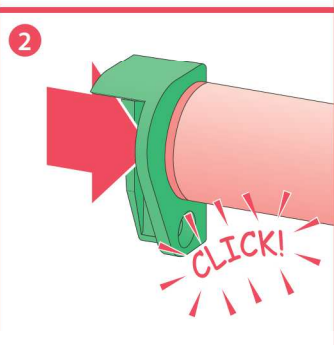
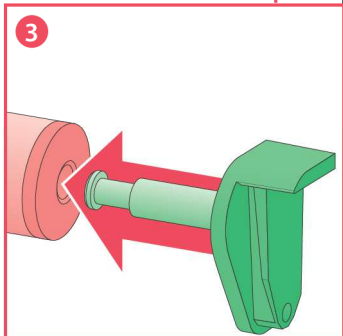
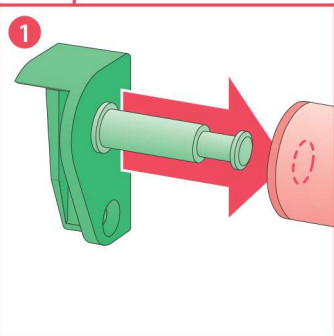
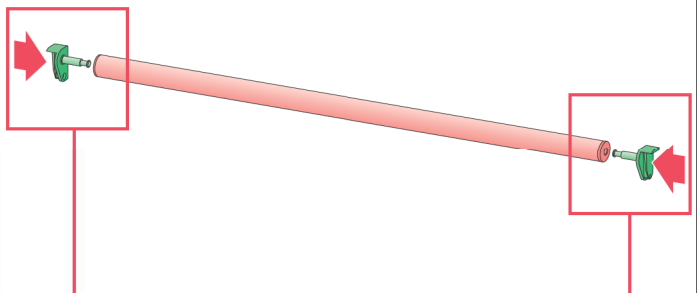

7b

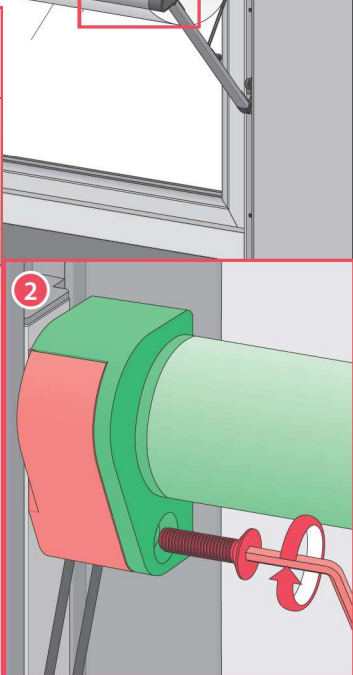
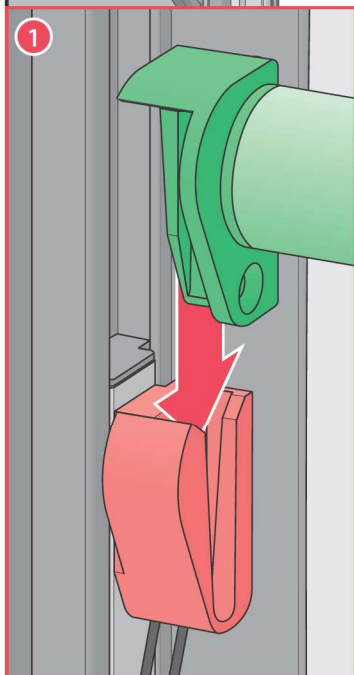
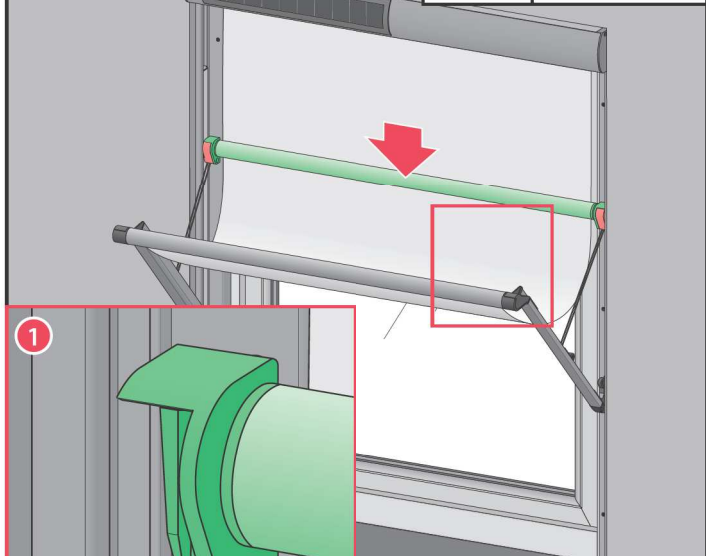

8

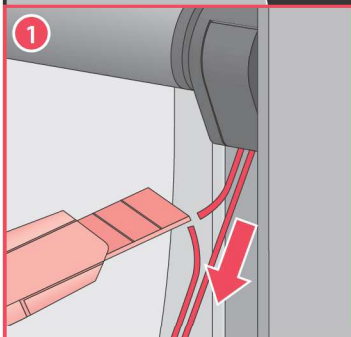
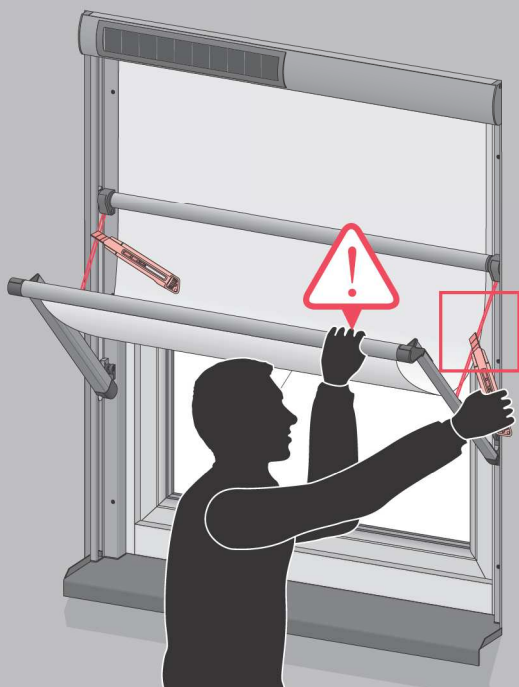

9

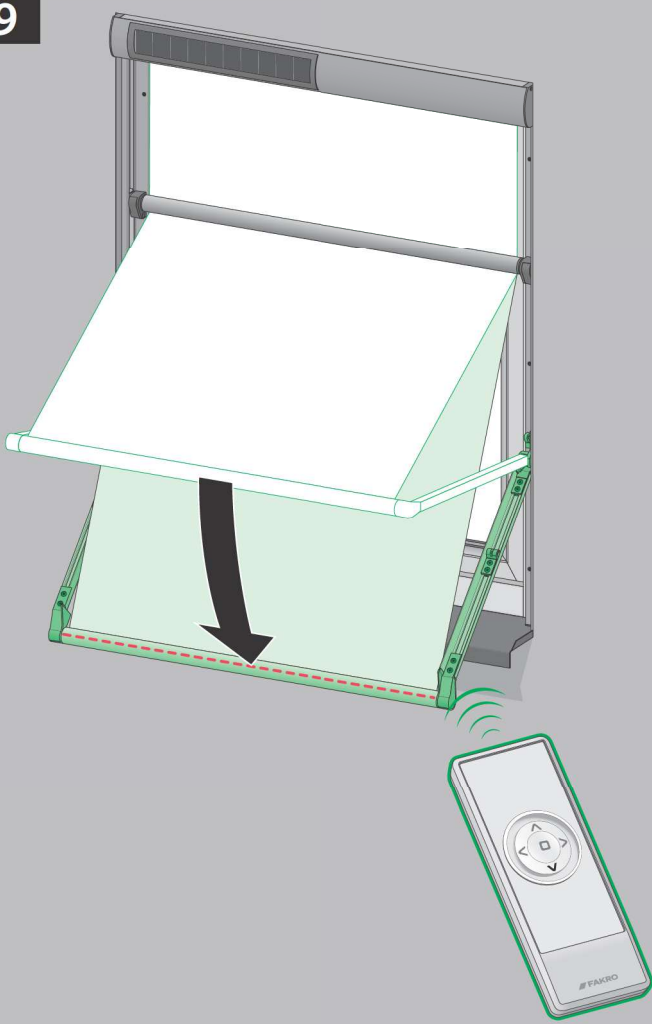

10a

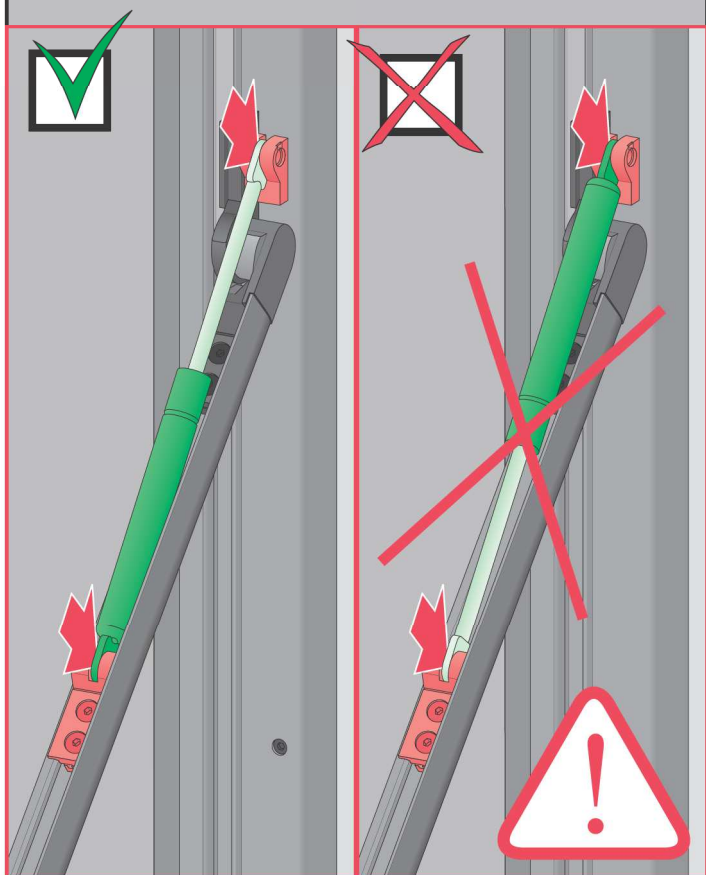
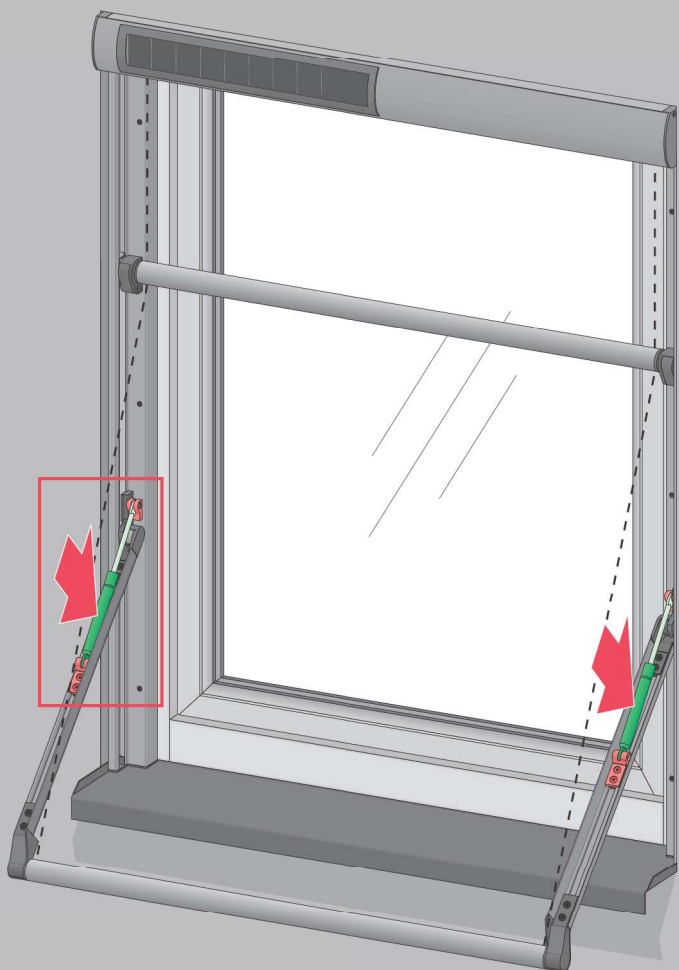
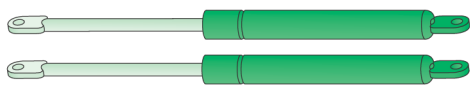

10b

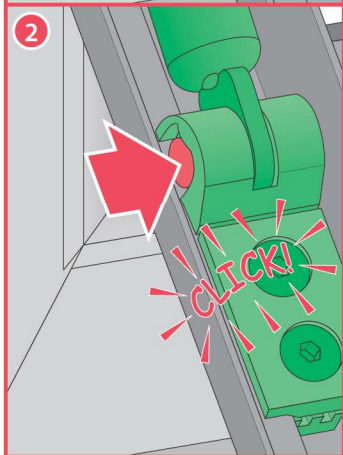
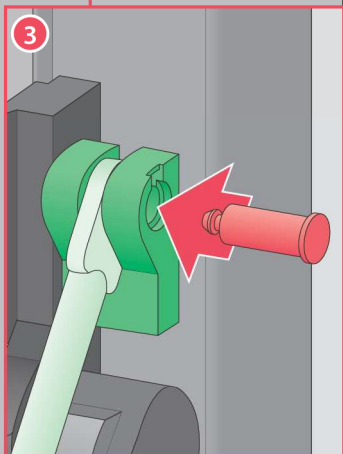
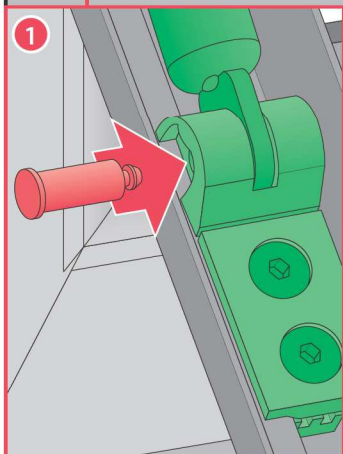
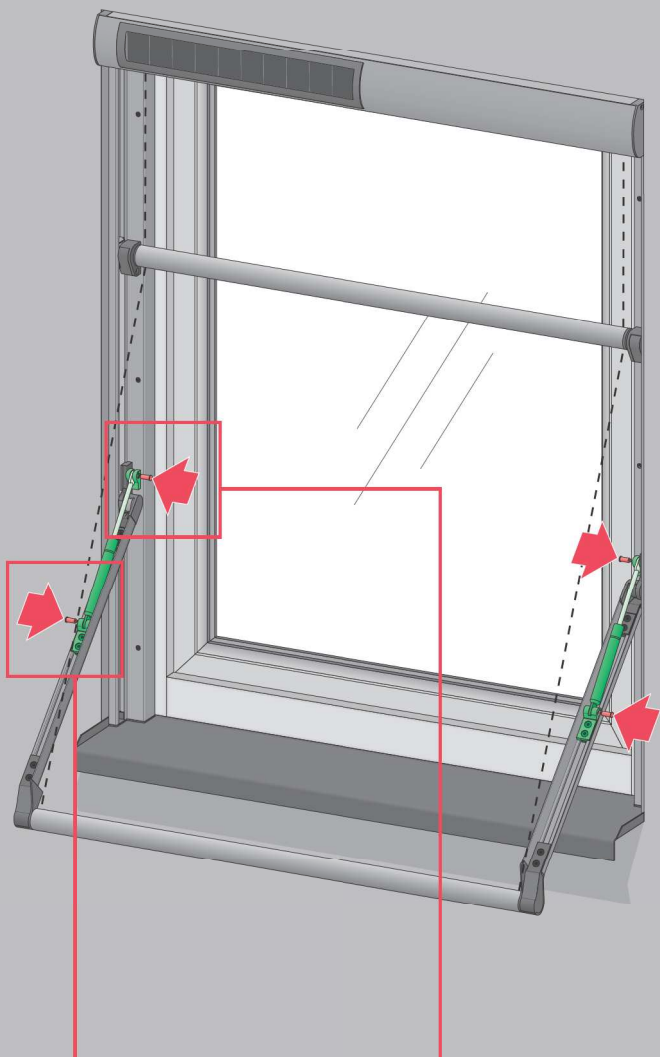
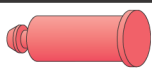

VMB Z-Wave Solar type C



11

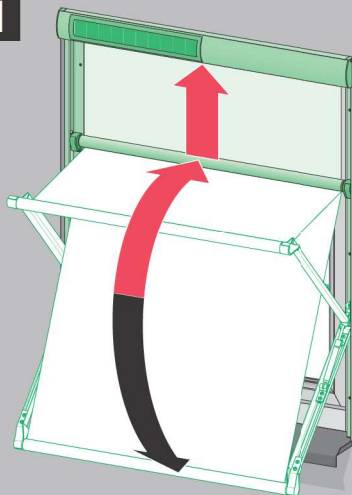

12

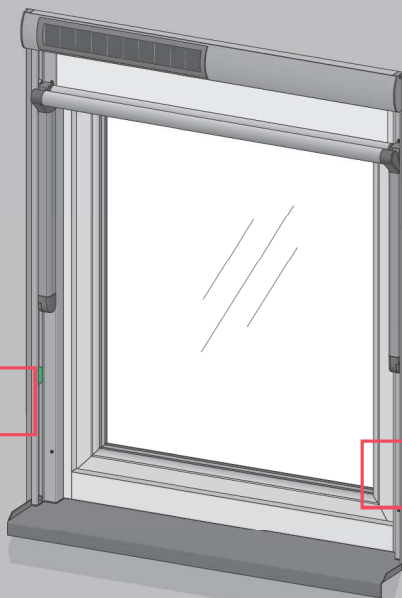

A=B

A

B



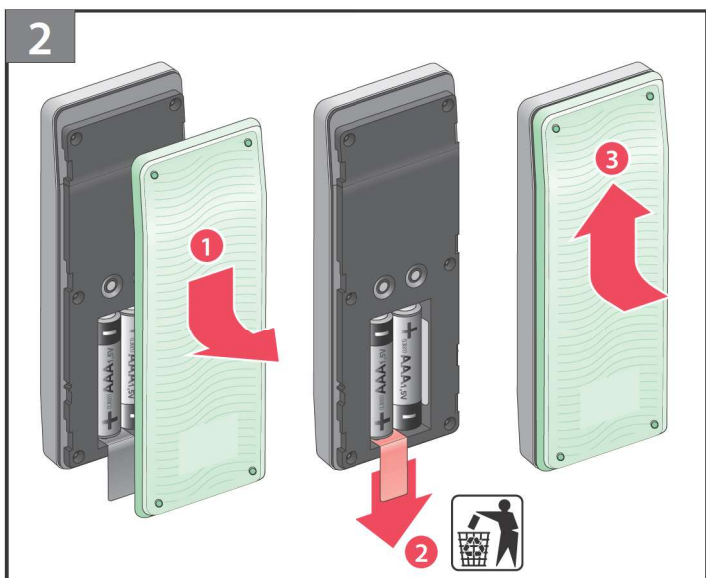
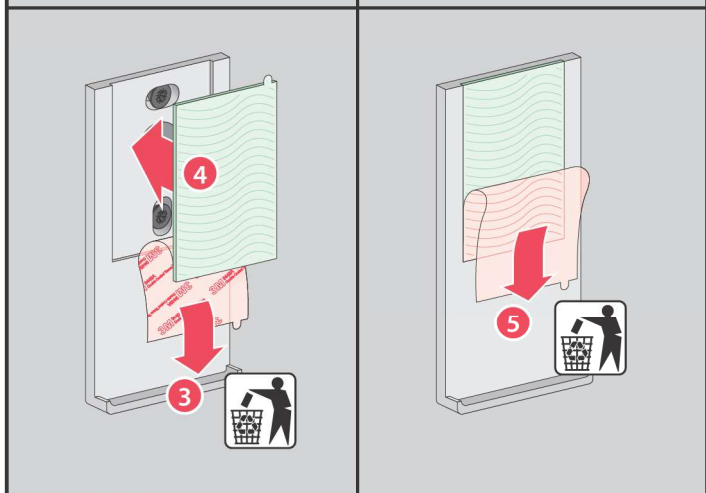
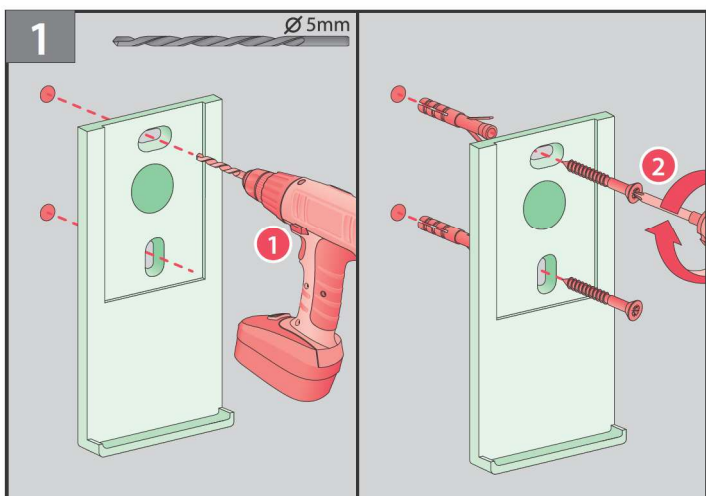

3a

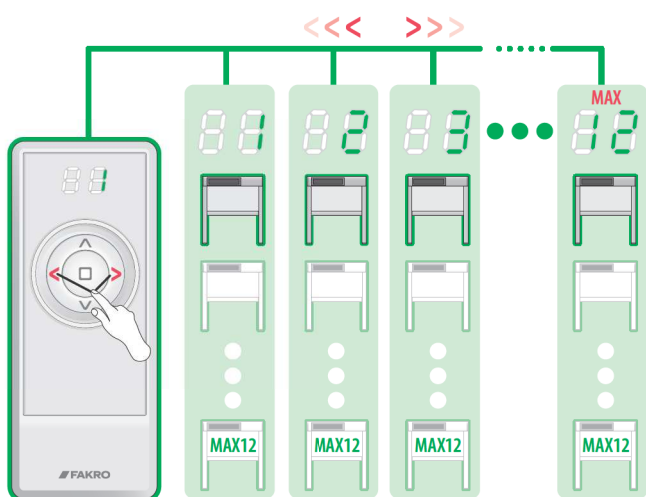

3b

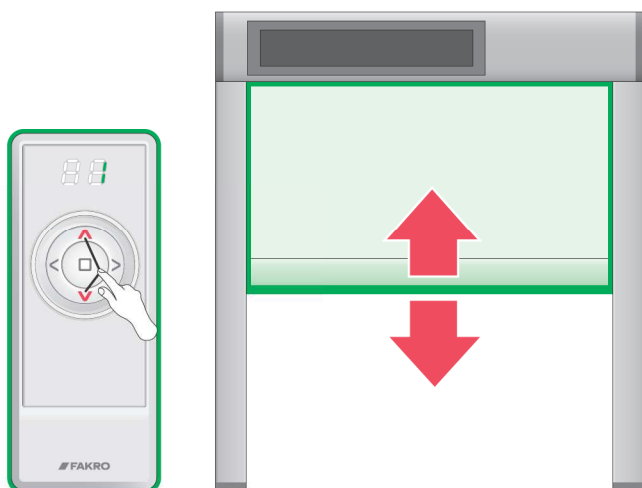

3c



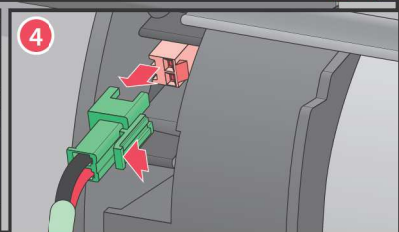
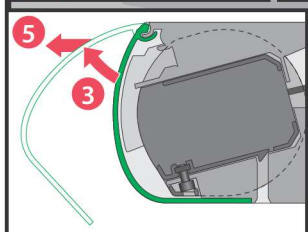
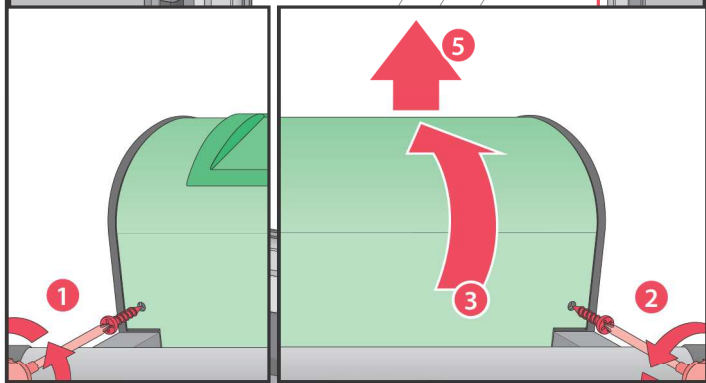
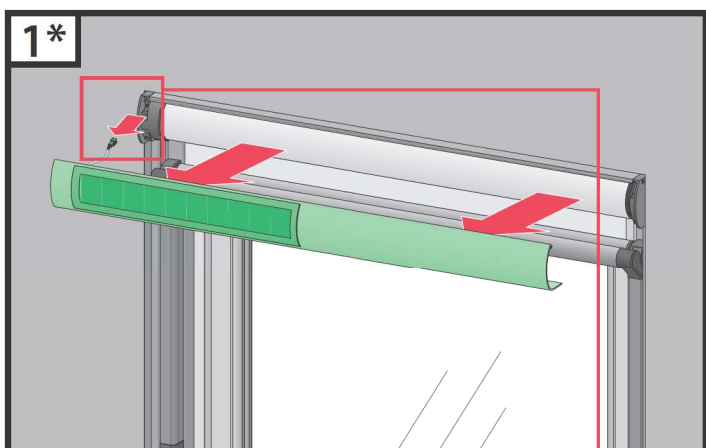
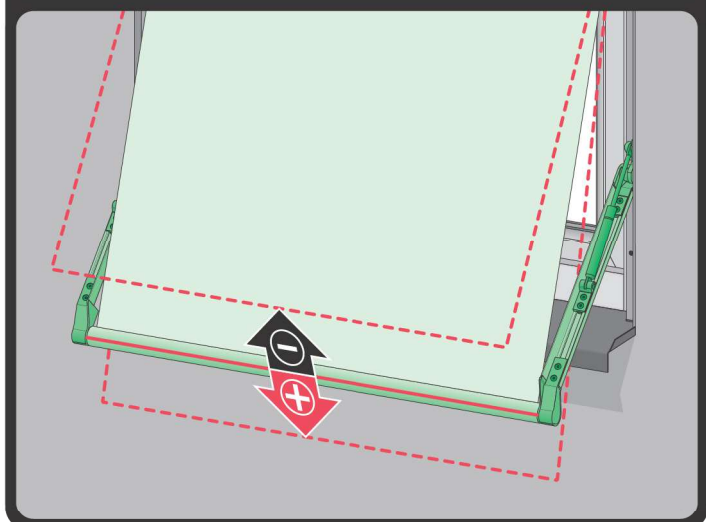
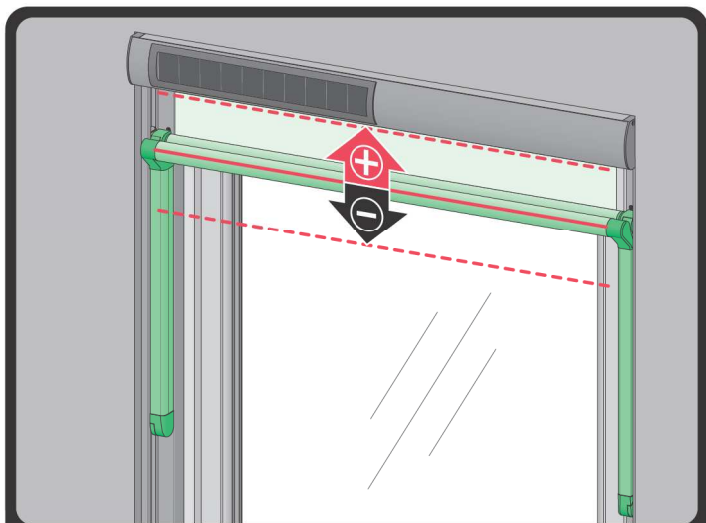

2a*

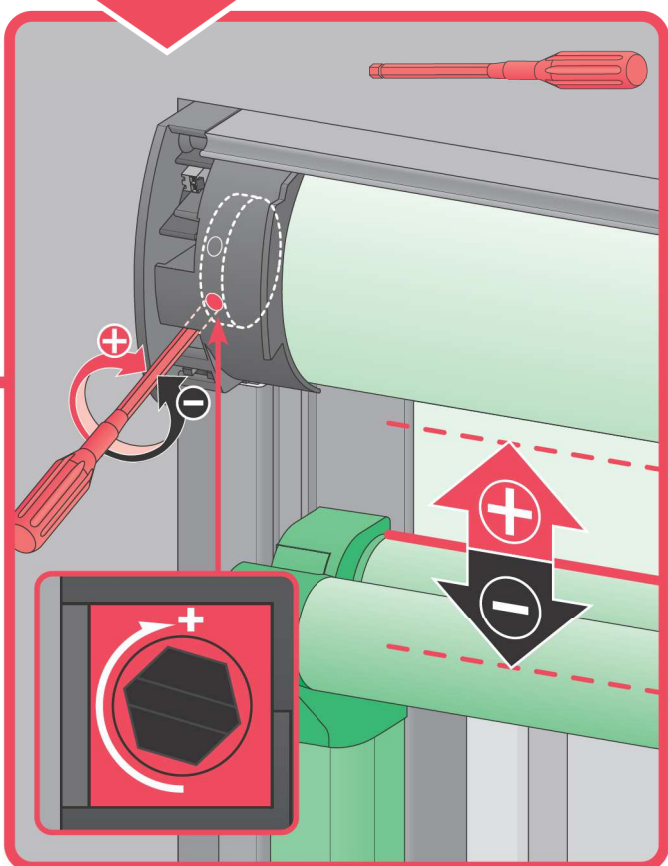
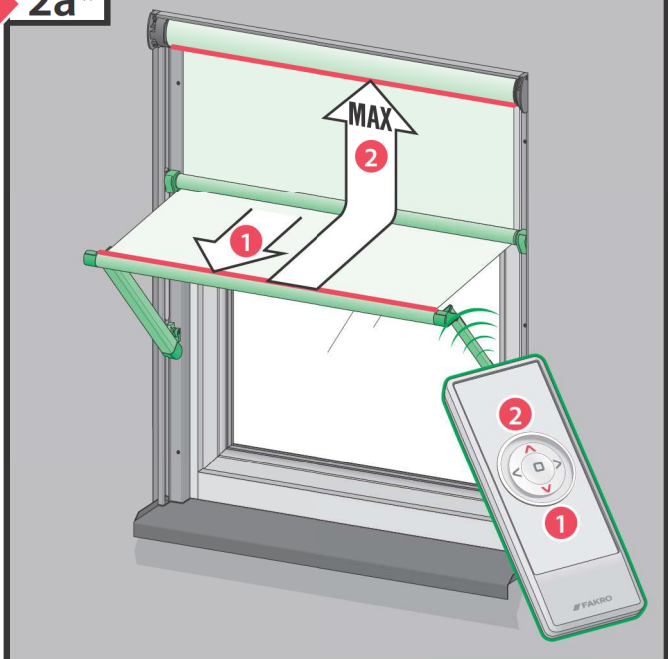

2b*

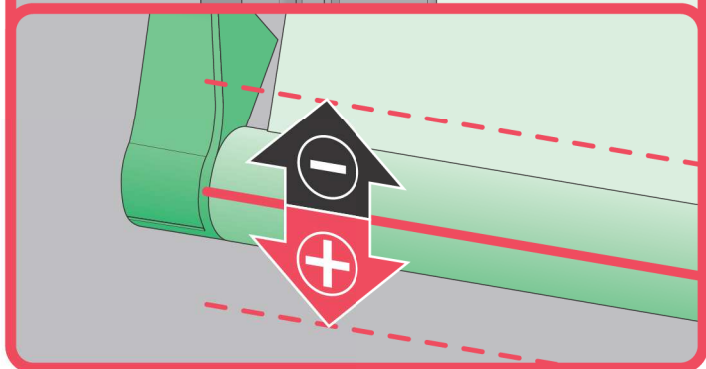
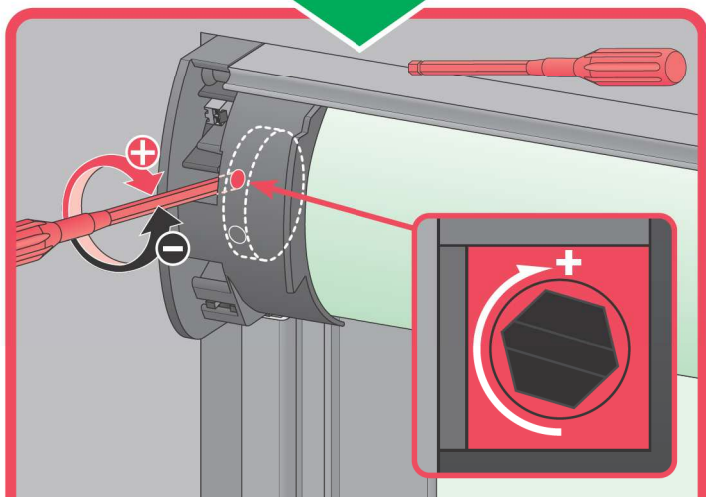
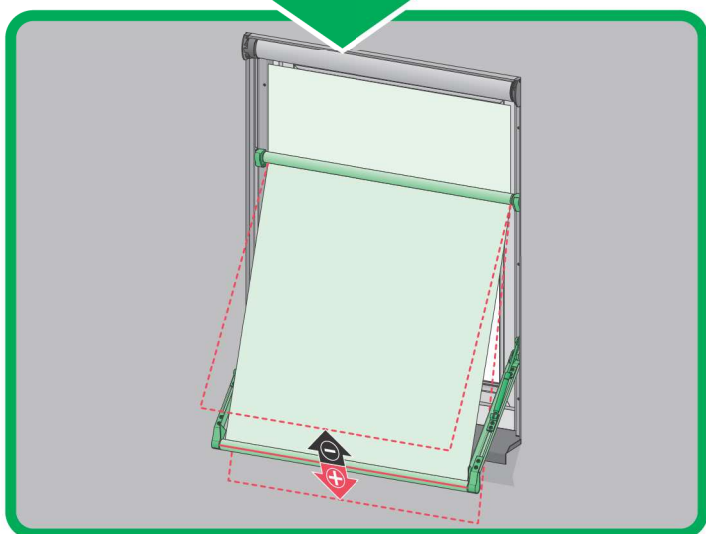
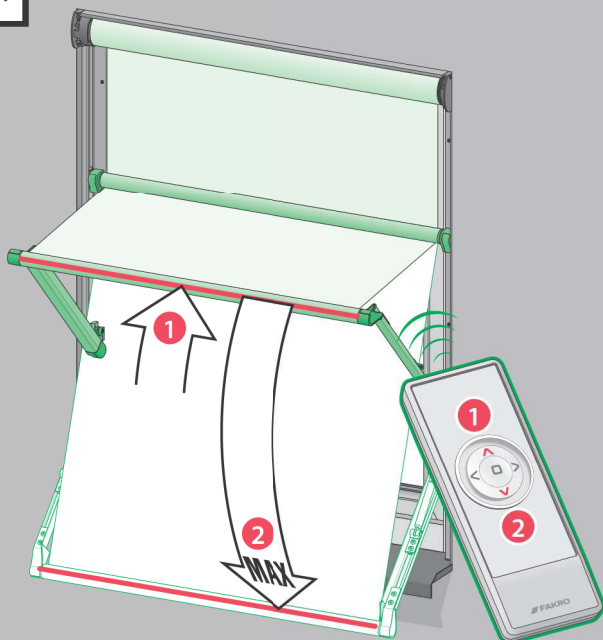

3*

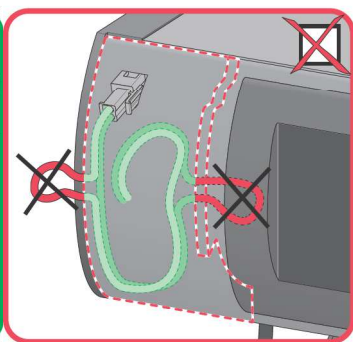
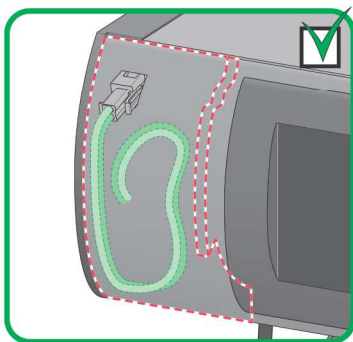
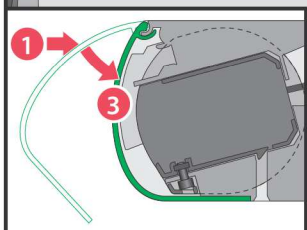
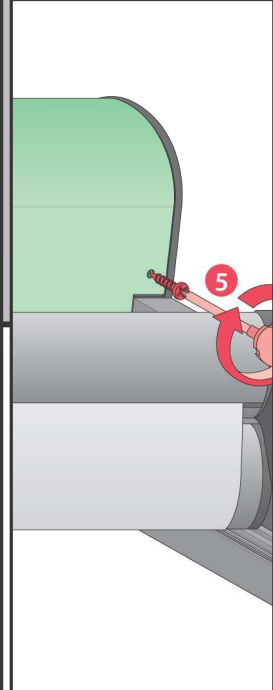
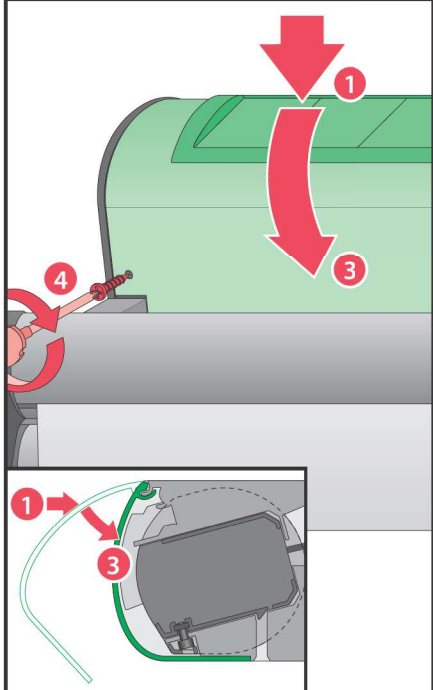
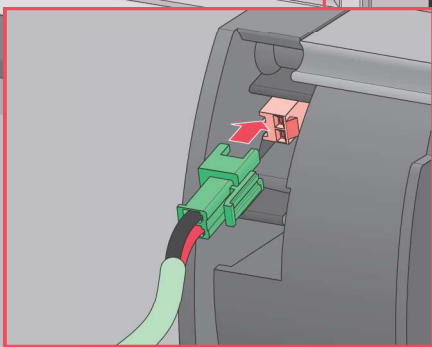
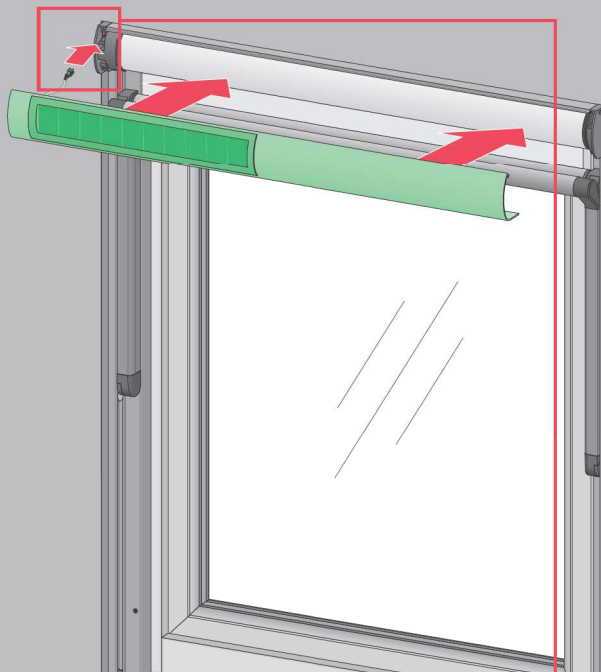

VMB Z-Wave Solar type C

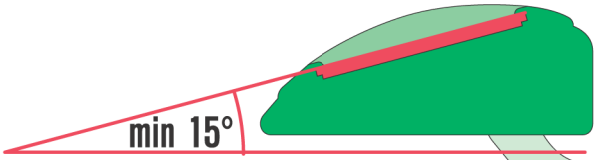
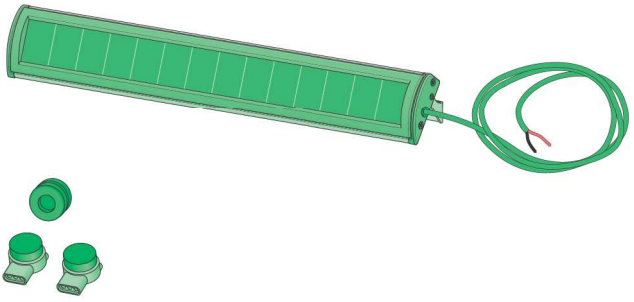

1

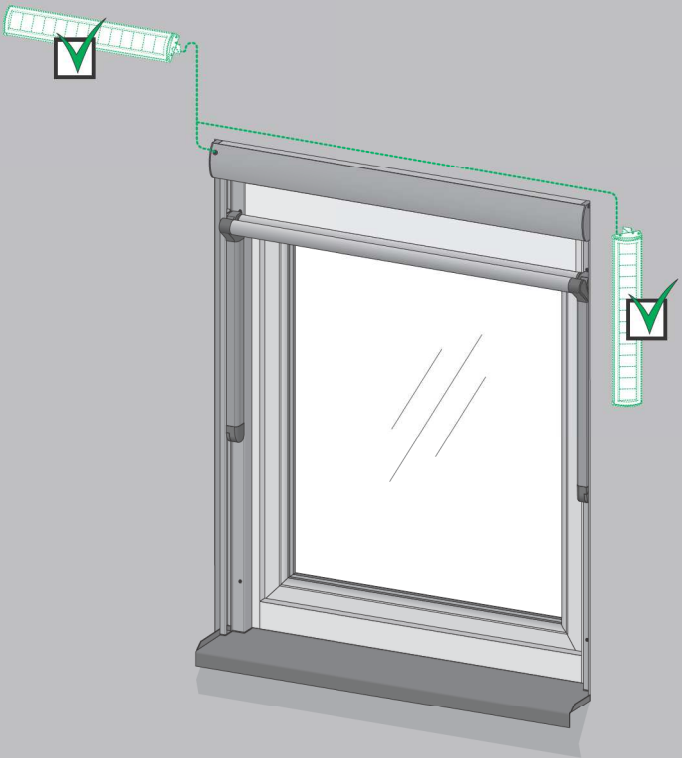

2

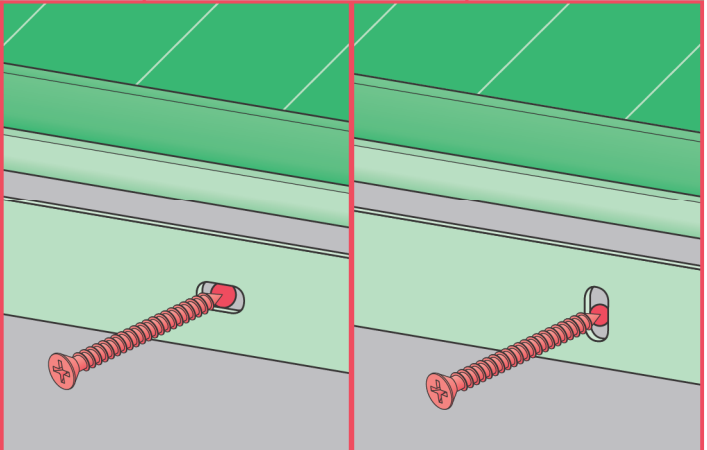
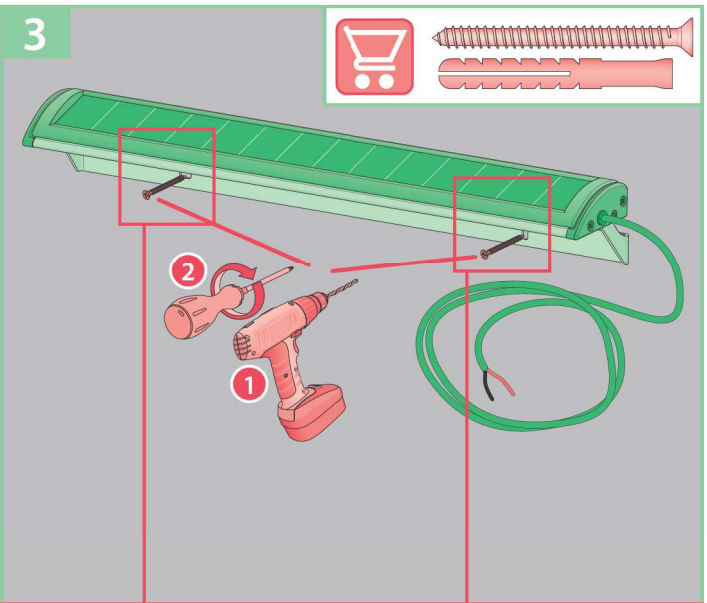
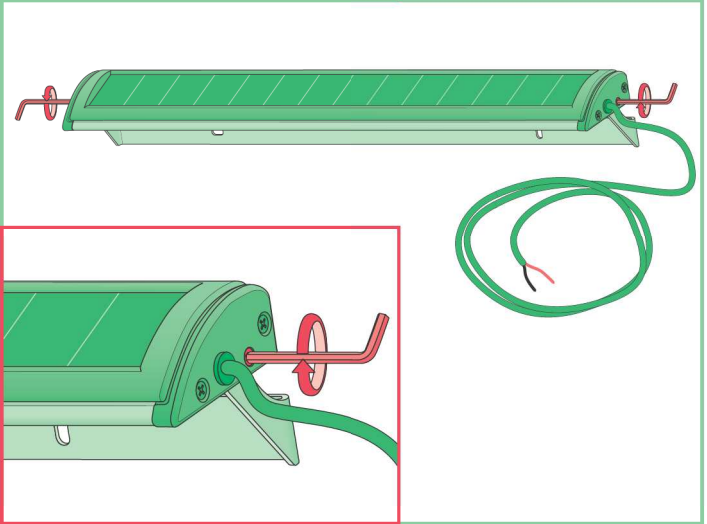
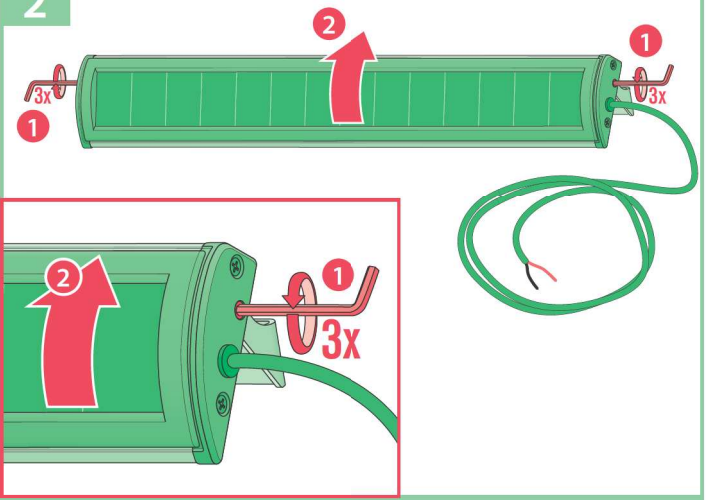

4

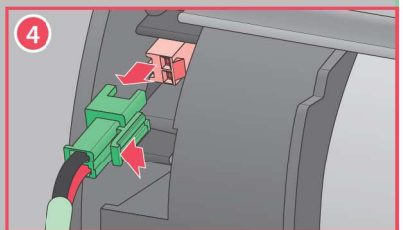
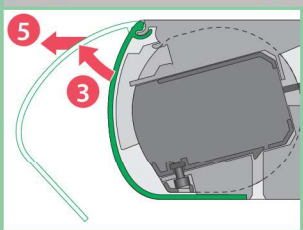
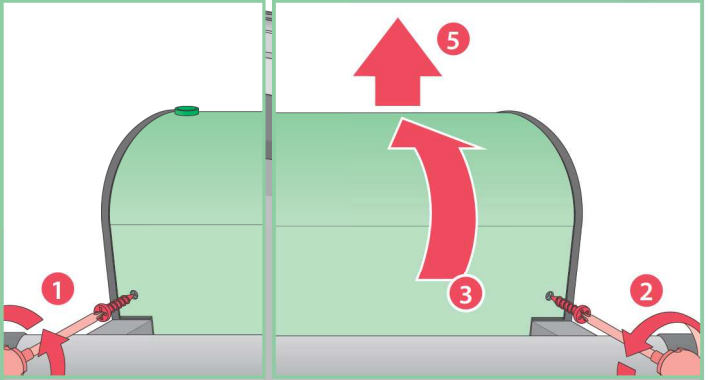
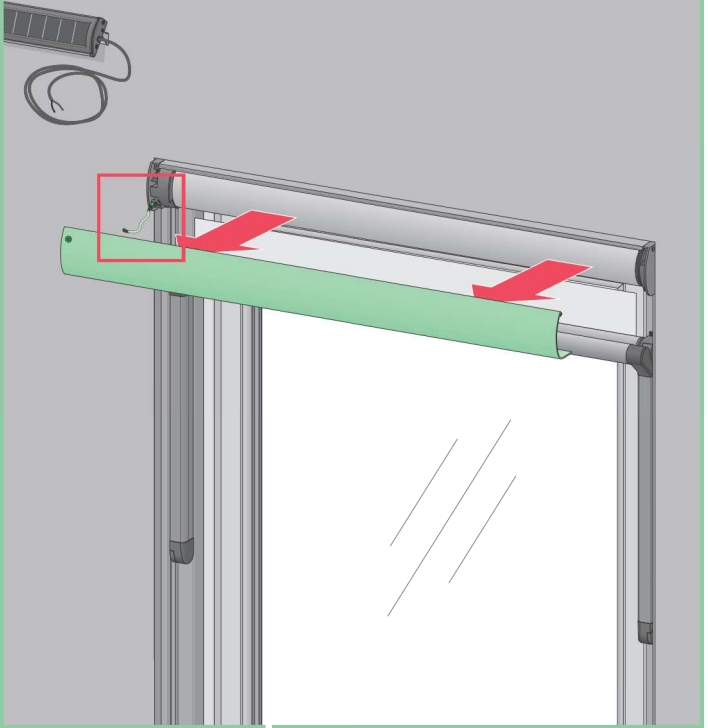

5a

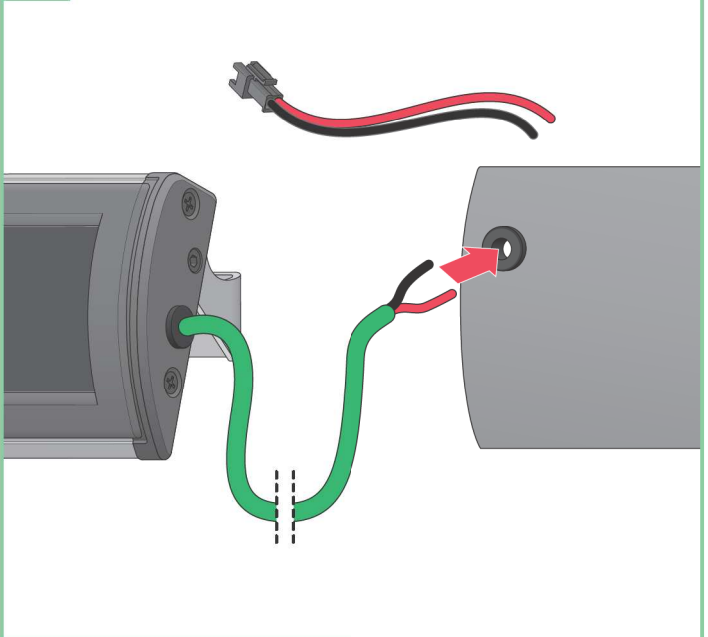

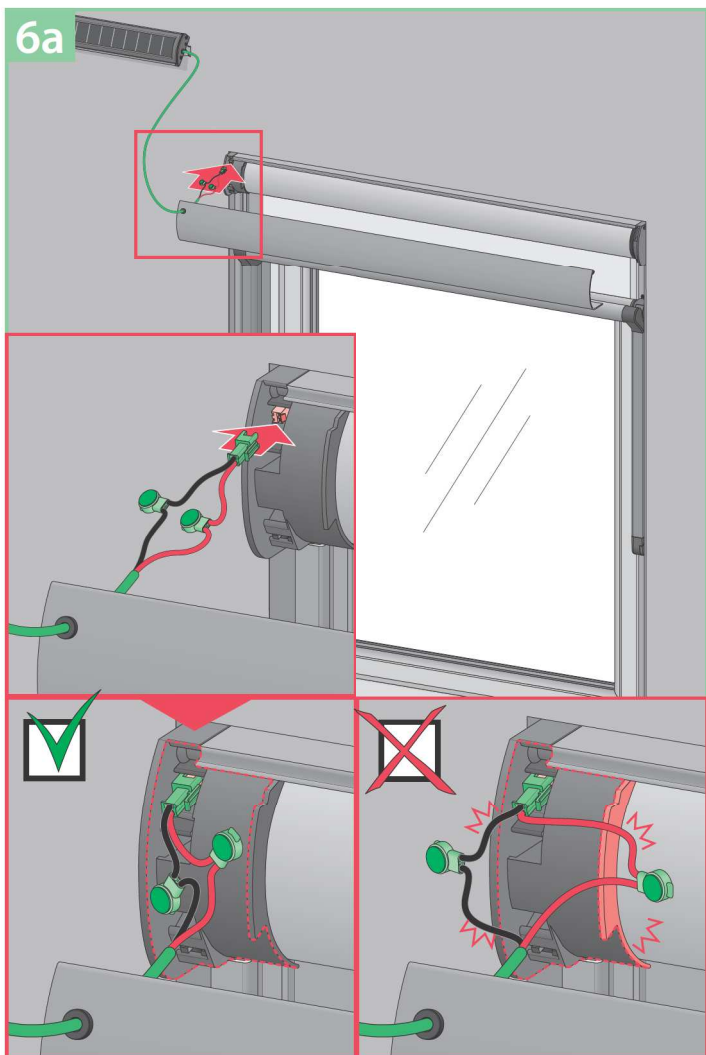
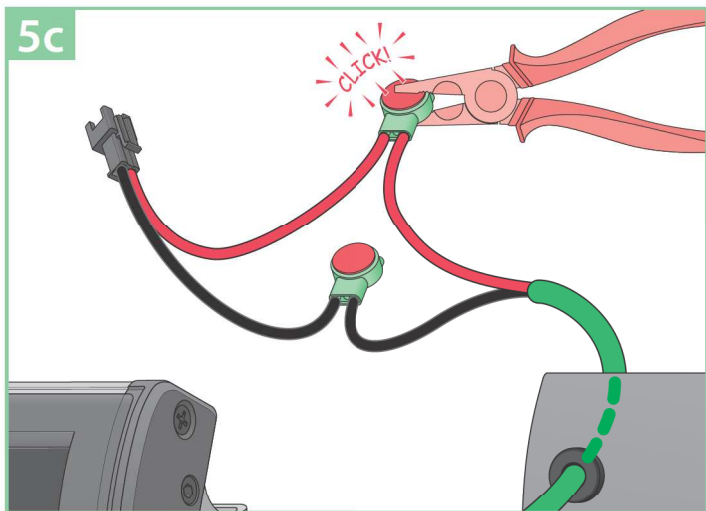
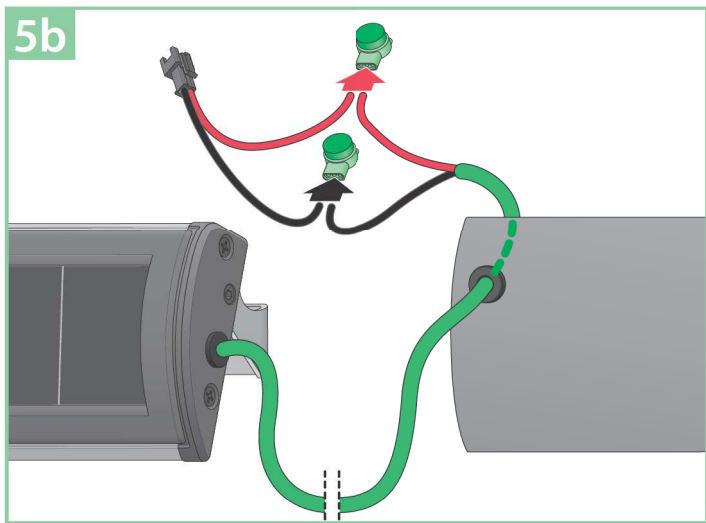

6b

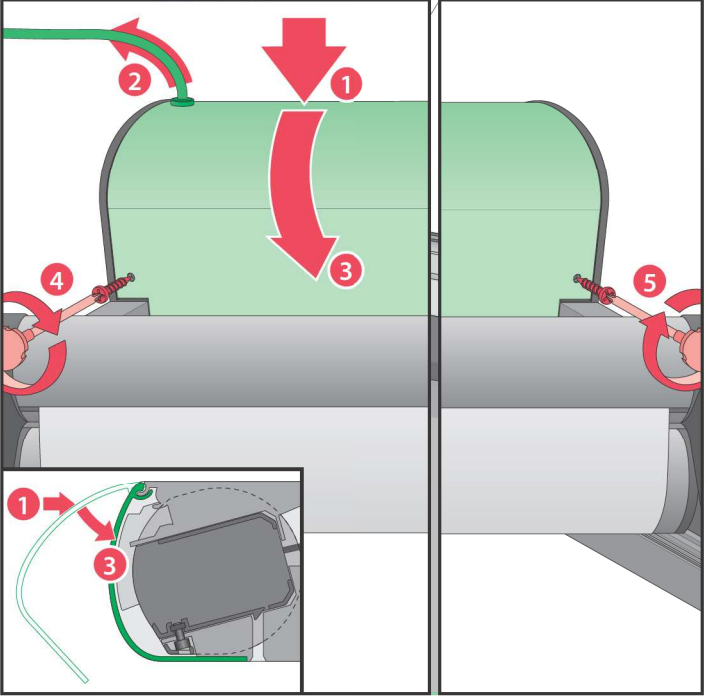
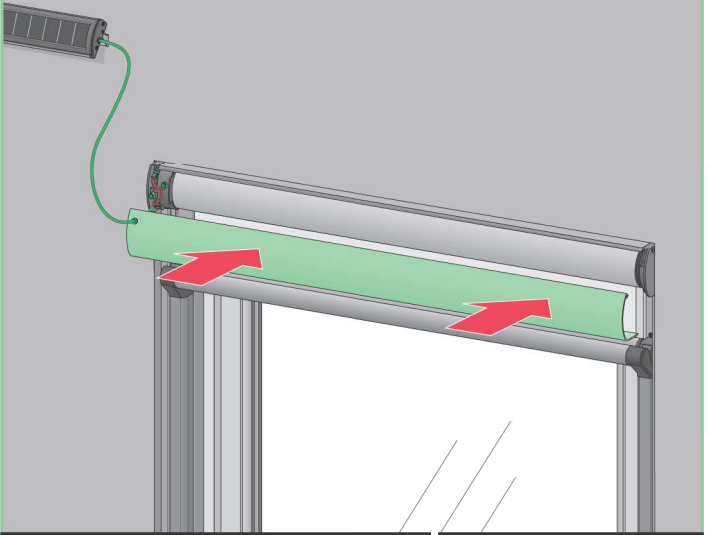

7

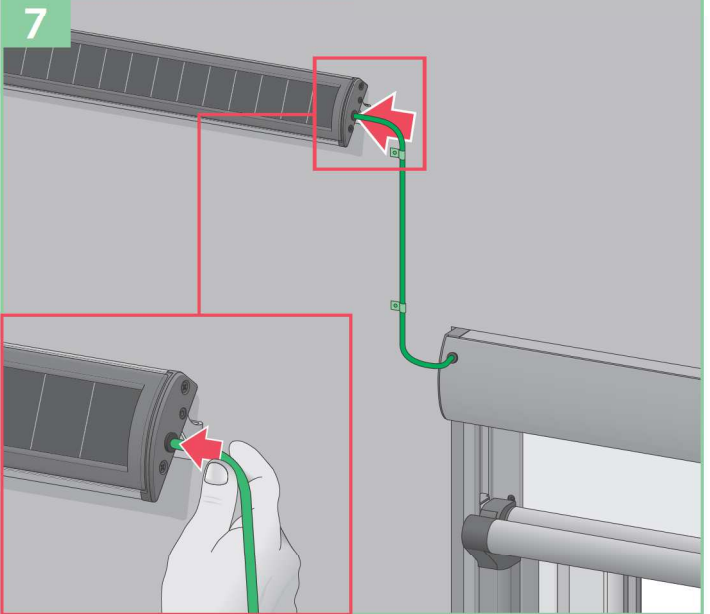

CZ	Před montáží si pozorně přečtěte návod NC867 „ORIGINÁLNÍ NÁVOD 2/3 Pravidla pro instalaci a použití“.
1	Odmontujte boční vodící lišty.
1a, 1b	Odmontujte krycí lištu z komory akumulátoru.
1c, 1d	Nainstalujte akumulátor, namontujte krycí lištu.
1e	Spojte boční vodící lišty s kazetou markýzolety.
2a	Umístěte markýzoletu do okenního otvoru.
2b	Zkontrolujte správnost montáže markýzolety.
3	Přišroubujte markýzoletu k oknu nebo k ostění.
4a	Nasadte dříve demontované profily na vodící lišty.
4b	Přišroubujte profily k vodícím lištám.
5	Vytáhněte trochu látku markýzolety.
6	Namontujte spodní lištu na ramena markýzolety.
7a, 7b	Namontujte napínací váleček.
8	Odstraňte zajišťovací provázek.
9	Spustte dolů markýzoletu.
10a	Umístěte plynové písky do vodících lišt.
10b	Zatlačte pojistné kolíky.
11	Zkontrolujte funkčnost markýzolety.
12	Nastavte polohu vyklápění spodní lišty pomocí blokad.
1*	V případě potřeby proveďte regulaci koncových poloh markýzolety.

DE	Lesen Sie vor der Montage die Anweisungen NC867 „ORIGINALANLEITUNG 2/3 Montage- und Nutzungsregeln“
1	Die seitlichen Führungsschienen demontieren.
1a, 1b	Entfernen Sie den Abdeckstreifen aus dem Batteriefach.
1c, 1d	Die Batterie einsetzen und die Abdeckleiste montieren.
1e	Die Seitenführungen mit der Kassette der Markisolette verbinden.
2a	Die Markisolette in die Fensteröffnung einbauen.
2b	Den korrekten Einbau der Markisolette kontrollieren.
3	Die Markisolette am Fenster oder an der Leibung festschrauben.
4a	Die zuvor demontierten Profile ordnungsgemäß in die Führungsschienen einsetzen.
4b	Die Profile an den Führungsschienen festschrauben.
5	Den Stoff der Markisolette etwas absenken.
6	Die Unterleiste in die Ausfallarme der Markisolette montieren
7a, 7b	Das Leitrohr montieren.
8	Die Sicherungsschnur abschneiden.
9	Das Markisentuch herunterlassen.
10a	Die Gasfedern in die Führungsschienen einsetzen.
10b	Die Sicherungsstifte eindrücken.
11	Die Funktion der Markisolette überprüfen.
12	Mittels Verriegelungen den Kippwinkel der unteren Leiste exakt einstellen.
1*	Bei Bedarf eine Justierung der Endstellungen der Markisolette durchführen.

EN	Before installation, it is compulsory to read the NC867 „ORIGINAL INSTRUCTIONS 2/3 Installation and user manual”.
1	Remove the side guide rails.
1a, 1b	Remove the cover strip from the battery compartment.
1c, 1d	Install the battery and install the cover strip.
1e	Connect the side guide rails with the awning cassette.
2a	Place the roll-up awning in the window opening.
2b	Check the roll-up awning for correct installation.
3	Screw the roll-up awning to the window or to the lining.
4a	Place the previously dismantled profiles in guide rails.
4b	Screw profiles to guide rails.
5	Lower slightly the roll-up awning fabric.
6	Install the bottom bar in the roll-up awning arms.
7a, 7b	Install the tube that makes the fabric deflect.
8	Cut off the safety string.
9	Roll down the roll-up awning fabric.
10a	Place gas springs in guide rails.
10b	Push in the safety mandrels.
11	Check the roll-up awning for correct operation.
12	Use the locks to set the bottom beam tilting moment.
1*	If required, adjust the end positions of the roll-up awning.

PL	Przed montażem należy zapoznać się z treścią instrukcji NC867 „INSTRUKCJA ORYGINALNA 2/3 Zasady montażu i użytkowania”.
1	Zdemontować prowadnice boczne.
1a, 1b	Zdemontować listwę maskującą z komory baterii.
1c, 1d	Zainstalować baterię, zamontować listwę maskującą.
1e	Połączyć prowadnice boczne z kasetą markizolety.
2a	Umieścić markizoletę w otworze okiennym.
2b	Sprawdzić poprawność montażu markizolety.
3	Przykręcić markizoletę do okna lub do szpalety.
4a	Umieścić zdemontowane wcześniej profile w prowadnicach.
4b	Przykręcić profile do prowadnic.
5	Opuścić nieco tkaninę markizolety.
6	Zamontować belkę dolną w ramieniach markizolety.
7a, 7b	Zamontować rurę przewojową.
8	Odciąć sznurek zabezpieczający.
9	Opuścić tkaninę markizolety.
10a	Umieścić sprężyny gazowe w prowadnicach.
10b	Wcisnąć trzpień zabezpieczający.
11	Sprawdzić działanie markizolety.
12	Za pomocą blokad ustawić moment odchylenia belki dolnej.
1*	W razie potrzeby przeprowadzić regulację pozycji krańcowych markizolety.

BG	Производител и Продавач не носят отговорност за неспазване на съответните закони, строителни норми и изисквания за безопасност от потребителя на продукта, архитекта, монтажника или собственика на сградата.	LT	Gamintojas ir pardavėjas neprisiima jokios atsakomybės už tai, kad gaminio naudotojas, architektas, montuotojas ar pastato savininkas nesilaiko galiojančiu įstatymu, taisykliu ir saugos reikalavimu.
CZ	Výrobce ani prodejce nenesou žádnou odpovědnost za nedodržení příslušných platných zákonů, stavebních předpisů a bezpečnostních požadavků uživatelem výrobku, architektem, montážníkem nebo vlastním budovy.	LV	Ražotājs un mazumtirdzniecības neuzņemas atbildību par likumu, noteikumu un drošības prasību neievērošanu no produkta lietotāja, arhitekta, uzstādītāja vai ēkas īpašnieka puses.
DE	Hersteller und Verkäufer übernehmen keine Haftung für Nichtbeachtung entsprechender Rechts- und Bauvorschriften sowie Sicherheitsanforderungen seitens Produktbenutzers, Architekten, Monteure oder Gebäudebesitzers.	NL	De fabrikant en verkoper zijn niet aansprakelijk voor gevolgen bij het niet opvolgen van toepasselijke wetten, bouwbesluiten en veiligheidsvoorschriften door de gebruiker van het product, de architect, de installateur of de eigenaar van het gebouw.
EE	Tootja ja jaemüüja ei vastuta toote kasutaja, arhitekti, paigaldaja või hoone omaniku poolt kehtivate seaduste, määruste ja ohutusnõuete mittejärgmise eest.	PL	Producent i Sprzedawca nie ponosi żadnej odpowiedzialności za nieprzebranie stosownych przepisów prawa, przepisów budowlanych i wymogów bezpieczeństwa przez użytkownika produktu, architekta, montażystę lub właściciela budynku.
ES	El fabricante y el vendedor no tienen ninguna responsabilidad por el incumplimiento de la ley vigente, normas de construcción y exigencias de seguridad por parte del usuario del producto, arquitecto, instalador o el propietario del edificio.	PT	O fabricante e o vendedor não tem nenhuma responsabilidade pelo o não cumprimento da lei, códigos de construção e as exigências de segurança por parte do usuário do produto, arquiteto, instalador ou proprietário do edifício.
FR	Le fabricant et le revendeur ne prend aucune responsabilité de ne pas respecter les lois applicables, les règlements sur les bâtiments et les exigences de sécurité par l'utilisateur du produit, l'architecte, l'installateur ou le propriétaire du bâtiment.	RO	Nici producătorul, nici distribuitorul nu își vor asuma niciun fel de răspundere pentru nerespectarea legilor în vigoare, a legilor din domeniul construcțiilor sau a măsurilor de siguranță impuse utilizatorilor produsului, arhitecților, montajistilor sau proprietarilor clădirii.
GB	Manufacturers and Sellers shall bear no liability for failure to comply with the applicable laws, building codes and safety requirements by the user of the product, architect, fitter or owner of the building.	RU	В случае несоблюдения архитектором, монтажником или владельцем здания строительных правил и норм безопасности ответственность с производителя и продавца снимается.
HU	A Gyártó és a Forgalmazó nem vállal semmilyen felelősséget a vonatkozó törvények, építési és biztonsági előírások, termékfelhasználói, építész, beszálló-mester vagy épülettulajdonos általi be nem tartásáért.	SI	Proizvajalec in prodajalec ne prevzemata odgovornosti za neupoštevanje ustreznih pravil in gradbenih predpisov ter varnostnih zahtev s strani uporabnika izdelka, projektanta, montažerja ali lastnika objekta.
IT	Il Produttore e il Rivenditore non potranno essere ritenuti responsabili per il mancato rispetto, da parte dell'utente del prodotto, del progettista, dell'installatore o del proprietario dell'edificio, delle leggi vigenti, nonché dei regolamenti edilizi e di quelli relativi alla sicurezza.	SK	Výrobca a predávca nenesú žiadnu zodpovednosť za nedodržanie príslušných ustanovení zákona, stavebných predpisov a bezpečnostných požiadaviek uživateľom výrobku, architektom, montérom alebo majiteľom objektu.